

MANUAL

to Install, Program, Operate and Maintain

ECOWATER[®]
S Y S T E M S



Your Water. Perfected.

MODEL EWS SERIES

COMMERCIAL WATER SOFTENERS / FILTERS with 2" Valve

If you have questions when installing, programming, operating or maintaining this system

CALL TOLL FREE: 1-800-627-3497



Designed, Engineered &
Assembled in the U.S.A.

EcoWater Systems LLC
P.O. Box 64420, St. Paul, MN 55164-0420
www.ecowater.com

7396965 (Rev. D 12/1/24)

TABLE OF CONTENTS

	<u>Page</u>
Shipment Inspection	3
Specifications	4
Dimensions	5
Planning Installation	6
Resin Loading & Assembly	7-12
Bottom Distributor Riser Pipe Length	7
Tank Neck Adaptor & Top Distributor Assembly	8
Aspirator Location, Upflow vs. Downflow Regeneration	9
Table: Nozzle/Venturi & Flow Controls	10
Identification of Nozzle & Venturi Parts	11
Typical Installation Plumbing	12
Installation Steps	13-15
Wiring Connection Diagram	16
Electronic Controller	17-26
Programming at Startup	17-20
Table: Controller Setup Information	21
Resetting Time	22
Features & Options	23-26
Lockout Feature	26
Operation, Valve Sequence / Water Flow Through Softener/Filter	27-31
Maintenance	32-35
Refilling with Salt	32
Breaking a Salt "Bridge"	32
Cleaning the Nozzle & Venturi	32
Relieving Water Pressure / Suggested Periodic Maintenance	33
Special Disassembly, Assembly Instructions / Aligning Valve with Drive Mechanism	33-35
Troubleshooting	36-40
Visual & Initial Checks / Automatic Electronic Diagnostics	36
Manual Electronic Diagnostics	37
Manual Advance Regeneration Check	38
Flow Plug Usage & Identification Chart	39-40
Repair Parts	42-47
Warranty	48

SAFETY GUIDES

Follow the installation instructions carefully. Failure to install the commercial system properly voids the warranty. Before you begin installation, read this entire manual. Then, obtain all the materials and tools you will need to make the installation.

Check local plumbing and electrical codes. The installation must conform to them. Use only lead-free solder and flux for all sweat-solder connections, as required by state and federal codes.

Do not locate this system where freezing temperatures occur. **Do not attempt to treat water over 100°F.** Freezing, or hot water damage voids the warranty.

Avoid installing in direct sunlight. Excessive sun heat may cause distortion or other damage to non-metallic parts.

The system requires a minimum water pressure of 30 psi at the inlet. **Maximum allowable Inlet water pressure is 125 psi.** If daytime pressure is over 80 psi, nighttime pressure may exceed the maximum. Use a pressure reducing valve if necessary (Adding a pressure reducing valve may reduce the flow).

The system works on **24V DC** electrical power only. Be sure to use the included power supply.

This system is not intended to be used for treating water that is microbiologically unsafe or of unknown quality without adequate disinfection before or after the system.

SHIPMENT INSPECTION

Thoroughly check the commercial system for possible shipping damage and/or parts loss. Also inspect and note any damage to shipping cartons, crating, etc. If damage is present, notify the transportation company. The manufacturer is not responsible for damage or parts loss in shipment.

NOTE: Do not mistakenly discard small parts bags when unpacking the system.

SOFTENERS

All softener models include:

- Resin tank
- Brine tank
- Controller
- Parts box

Another kit includes the aspirator and drain flow control assemblies. The mineral bed consists of one cubic foot bags of water softening resin, and 50 pound bags of various grades of gravel. Refer to the chart below.

Duplex softeners include 2 resin tanks and 1 brine tank, controller, parts box, aspirator and drain flow control assemblies, and double amounts of resin and gravel shown in the table below.

Triplex softeners include 3 resin tanks and 2 brine tanks, controller, parts box, aspirator and drain flow control assemblies, and triple amounts of resin and gravel shown in the table below.

Quadplex softeners include 4 resin tanks and 2 brine tanks, controller, parts box, aspirator and drain flow control assemblies, and quadruple amounts of resin and gravel shown in the table below.

FILTERS

Filters do not include brine tank or aspirator assemblies.

Duplex filters include 2 resin tanks, controller, parts box, drain flow control assemblies, and double amounts of media.

Triplex filters include 3 resin tanks, controller, parts box, drain flow control assemblies, and triple amounts of media.

Quadplex filters include 4 resin tanks, controller, parts box, drain flow control assemblies, and quadruple amounts of media.

NOTE: This manual includes all duplex, triplex, quadplex softeners and filters also.

		Water Softener Model								
		102, 102-1	132, 132-1	162, 162-1	192, 192-1	252, 252-1	322, 322-1	362	452	602
1 cu. ft. Bags of Resin		3	4	5	6	8	10	12	15	20
Bags of Gravel (lbs)	Fine	1 (50)	1 (50)	1 (50)	2 (50)	2 (50)	2 (50)	3 (50)	3 (50)	5 (50)
	Medium	1 (50)	1 (50)	1 (50)	2 (50)	2 (50)	2 (50)	3 (50)	3 (50)	5 (50)

		Filter Model									
		Carbon				Greensand			Multimedia		
		172C, 172C-1	242C, 242C-1	302C	362C	172G, 172G-1	242G, 242G-1	302G	172M, 172M-1	242M, 242M-1	302M
Mineral (cu. ft.)		4	10	15	20	3	6	9	–	–	–
Other Mineral (lbs.)	Anthracite	–	–	–	–	78*	156	260	156	312	520
	Garnet	–	–	–	–	50	150	200	50	150	200
Bags of Gravel (lbs)		2 (50)	3 (50)	5 (50)	6 (50)	2 (50)	3 (50)	5 (50)	2 (50)	3 (50)	5 (50)
Filter Sand (lbs)		–	–	–	–	–	–	–	100	250	350

* Partial bag

SPECIFICATIONS

		Water Softener Model									Filter			
		102, 102-1	132, 132-1	162, 162-1	192, 192-1	252, 252-1	322, 322-1	362	452	602	172, 172-1	242, 242-1	302	362
Capacity (grains) @ Salt Usage^①	4 lbs./cu.ft.	54K	72K	90K	108K	144K	180K	216K	270K	360K	NA	NA	NA	NA
	6 lbs./cu.ft.	72K	96K	120K	144K	192K	240K	288K	360K	480K	NA	NA	NA	NA
	8 lbs./cu.ft.	84K	112K	140K	168K	224K	280K	336K	429K	560K	NA	NA	NA	NA
	10 lbs./cu.ft.	93K	124K	155K	186K	248K	310K	372K	465K	620K	NA	NA	NA	NA
	12 lbs./cu.ft.	99K	132K	165K	198K	264K	330K	396K	495K	660K	NA	NA	NA	NA
Amount of Media^② (cu. ft.)		3	4	5	6	8	10	12	15	20	4	10	15	20
Salt Storage Capacity (lbs.)		1000	1000	1000	1500	1500	1500	1500	1500	2500	NA	NA	NA	NA
Water Supply Max. Clear Water Iron (ppm)		5	5	5	5	5	5	5	5	5	Dependent on Application			
Maximum Drain Flow Rate (gpm)		7	7	7	12	12	12	24	24	32	15* 24**	30* 50**	50* 70**	70*
Water Pressure Loss (PSI)														
Flow Rate (gpm) & Pressure (PSI) Loss (ΔP)^③	10 gpm	1.5 ΔP	2 ΔP	2.5 ΔP	1 ΔP	1 ΔP	1 ΔP	–	–	–	–	–	–	–
	20 gpm	3.5 ΔP	4.5 ΔP	5 ΔP	2 ΔP	2.5 ΔP	3 ΔP	2 ΔP	2.5 ΔP	–	–	–	–	–
	30 gpm	6 ΔP	7.5 ΔP	9 ΔP	4 ΔP	4.5 ΔP	5 ΔP	3.5 ΔP	4 ΔP	3 ΔP	–	–	–	–
	40 gpm	9 ΔP	11 ΔP	13 ΔP	6.5 ΔP	7 ΔP	7.5 ΔP	5.5 ΔP	6 ΔP	5 ΔP	–	–	–	–
	50 gpm	12.5 ΔP	15.5 ΔP	18 ΔP	9 ΔP	9.5 ΔP	10.5 ΔP	7.5 ΔP	8 ΔP	7 ΔP	–	–	–	–
	60 gpm		20 ΔP	23 ΔP	12 ΔP	12.5 ΔP	14 ΔP	10 ΔP	11 ΔP	9 ΔP	–	–	–	–
	70 gpm			29 ΔP	15 ΔP	16 ΔP	18 ΔP	13 ΔP	14 ΔP	12 ΔP	–	–	–	–
	80 gpm				19 ΔP	20 ΔP	22 ΔP	16 ΔP	17 ΔP	15 ΔP	–	–	–	–
	90 gpm					24 ΔP	26 ΔP	20 ΔP	21 ΔP	18 ΔP	–	–	–	–
	100 gpm							23 ΔP	25 ΔP	21 ΔP	–	–	–	–
	110 gpm							27 ΔP	29 ΔP	25 ΔP	–	–	–	–
Water Supply Pressure Range (PSI)		30 - 125												
Water Supply Temperature Range (°F)		35 - 100												
Electrical Rating		24V DC												

- ① UP flow regeneration
- ② Synthetic high capacity resin or selected filtering material
- ③ Peak flows for intermittent use only
- * Flows for carbon filters
- ** Flows for greensand and multimedia filters

If you have questions when installing, programming, operating or maintaining this system

CALL TOLL FREE: 1-800-627-3497

DIMENSIONS

Minimum Floor Space Required

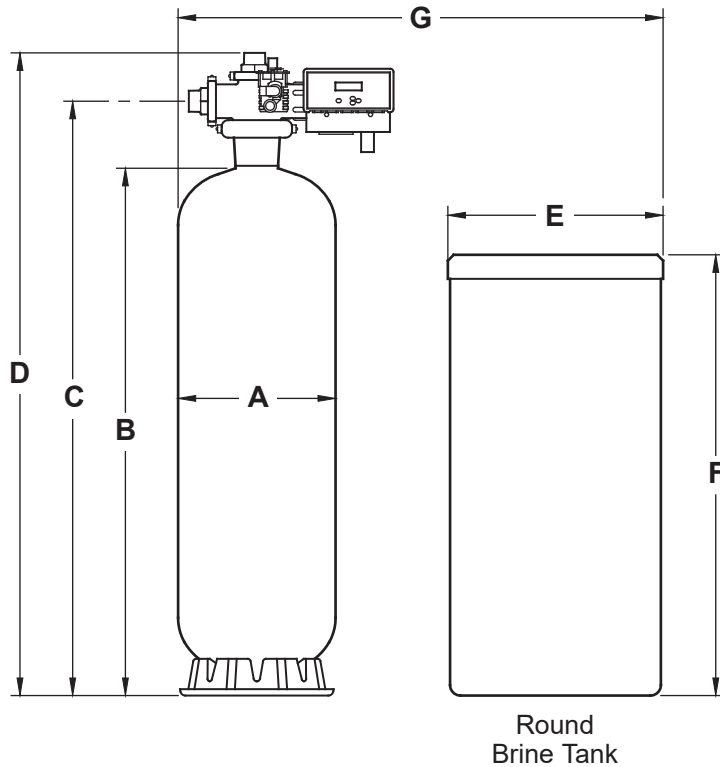

	MODEL	A Nominal Resin Tank Diameter	B Nominal Resin Tank Height	C Inlet - Outlet Height	D Overall Height	E Brine Tank Diameter	F Brine Tank Height	G		INLET - OUTLET Pipe Size	DRAIN Pipe Size (recom. minimum)
								Single	Twin		
Softeners	102, 132	17"	58"	66-1/4"	71-3/4"	24"	50"	45"	66"	2"	3/4"
	102-1, 132-1	16"	65"	73-1/16"	78-9/16"						
	162	17"	72"	80-1/4"	85-3/4"	24"	50"	45"	66"	2"	3/4"
	162-1	18"	65"	75-1/16"	80-9/16"						
	192, 252, 322	24"	72"	80-1/2"	85-3/4"	31"	51"	59"	87"	2"	3/4"
	192-1, 252-1, 322-1			82-3/4"	88-1/4"						
	362, 452	30"	72"	82-3/8"	88-3/4"	31"	51"	65"	99"	2"	1"
	602	36"	72"	82-3/8"	88-3/4"	41"	51"	81"	121"	2"	1"
Filters	172	17"	58"	66-1/4"	71-3/4"	NA	NA	17"	50"	2"	1 - 2" *
	172-1	16"	65"	73-1/16"	78-9/16"						
	242	24"	72"	80-1/4"	85-3/4"	NA	NA	24"	54"	2"	1 - 2" *
	242-1			82-3/4"	88-1/4"						
	302	30"	72"	82-3/8"	88-3/4"	NA	NA	30"	66"	2"	1 - 2" *
	362	36"	72"	82-3/8"	88-3/4"	NA	NA	36"	78"	2"	1 - 2" *

* Varies with filter application. Iron filters, requiring higher backwash flows, need 2" drains. Also, drain pipe size should increase with longer drain runs.

PLANNING FOR LOCATION & INSTALLATION OF SYSTEM

WATER SUPPLY

The system requires a potable water supply that will provide a continuous flow to meet regeneration flow specifications. A minimum pressure of 30 psi is required at the conditioner inlet.

BOTH HOT & COLD WATER CONDITIONING

Connect the system to the water supply pipe, immediately after (downstream of) the municipal supply water meter or well supply pressure tank. To provide unconditioned water to isolated faucets, if desired, run separate pipes from the water supply before (upstream of) the system.

CONDITIONING HOT WATER ONLY

Connect the system to the water supply pipe before (upstream of) the water heater.

CAUTIONS: (1) **Do not** install the conditioner after (downstream of) the water heater. **Hot water will damage** inner parts of the system, and may cause the loss of the water conditioner mineral bed. (2) To reduce the risk of hot water backing up into the conditioner, piping between the conditioner and water heater should be as long as possible.

DRAIN

A drain is needed nearby the conditioner, capable of carrying away backwash water at the rate of flow listed in the specifications. A floor drain is preferred. Other approved drain points are acceptable, if they do not cause a back-pressure on the conditioner drain pipe or hose. A floor drain is needed for the overflow on the salt tank.

ELECTRICAL

The system works on **24V DC only**. A direct plug-in power supply is included to reduce 120V AC, 60 Hz electrical power to 24V DC. An approved, grounded outlet is needed near the system controller. The system includes a power cable to connect between the power supply and the controller.

SPACE REQUIREMENTS

Be sure to allow sufficient area around the resin and brine tanks for refilling with salt and other service. Minimum floor space and other dimensions are shown on page 5.

MATERIALS YOU MAY NEED

Use the drawing on page 12 as a guide for your installation. The drawing shows typical connection using fittings included with the system, and with optional items available.

- Be sure to install a 3-valve bypass system. Bypass valves allow you to turn off water to the system, for servicing, while having full-line bypass to the establishment.
- A minimum inside diameter hose or pipe is required for the conditioner valve drain (see page 5). The drain connection at the valve is 2" male pipe thread. Also, on softeners, a length of 5/8" I.D. garden hose is needed for the drain overflow on brine tanks.
- For inlet and outlet pipes to the conditioner, use copper, CPVC plastic, or threaded pipe and fittings. Avoid joining copper and galvanized together as corrosion will occur rapidly. The valve inlet and outlet connections are 2" male pipe thread.

RESIN LOADING & ASSEMBLY

1. Move the resin tank into installation location (see page 6). Set it on a flat, level surface. If a multiple installation, keep tanks separated for ease of service.

Note: Steps 2 and 3 may be done in an area other than installation location if space is limited. Verify that the bottom distributor is hand tightened on to the riser tube.

2. On 30" & 36" Tanks: Install tank neck adaptor 7345516.

3. On All Tanks: Place the bottom distributor into the resin tank and center it. Check the distributor length, as shown in Figure 1, and adjust it as needed. **It must extend between 2-5/8" and 3" above the top of the tank (or that distance above the top of the adaptor on 30" and 36" units).**

Cut end square using a hacksaw or pipe cutter. Bevel the top edge and smooth with sandpaper or a file. Tip the distributor upside-down and tap gently to remove plastic shavings from inside.

4. With a pail or hose, fill the tank with 1 to 2 feet of water. The water acts as a cushion to protect the bottom distributor while filling the tank with gravel, resin or other minerals.

5. Plug the end of the distributor tube with a clean rag, to keep gravel and resin out. Then, place into the tank and center.

6. Using a larger neck funnel, add the specified (see page 2) amount of gravel. **Be sure the distributor remains centered and resting on the tank bottom.**

Note: When coarse, medium and fine gravels are specified, add in that order.

Note: For a **multi-media** filter, add gravel, garnet, filter sand, and anthracite, in that order.

Note: For a **greensand** filter, add gravel, garnet, greensand, and anthracite, in that order.

7. Add the specified amount of resin, or filtering minerals, using water sparingly to speed flow through the funnel.

Resin Tank Size	Freeboard Range*
16" x 65"	19" - 24"
17" x 58"	17" - 21"
18" x 65"	19" - 23"
17" x 72"	22" - 26"
24" x 72"	22" - 26"
30 x 72"	22" - 26"
36 x 72"	22" - 26"

*Freeboard range, in the preceding chart, is provided only as a guide for maintenance. Freeboard can vary several inches, depending on resin bed conditions including... if regenerated or exhausted, total moisture content, settling during shipping and storage, tolerance variables in resin tank size, and amount and type of gravel underbedding.

8. Flush the tank opening with water to clean resin beads from the top of the tank. Then, remove the rag

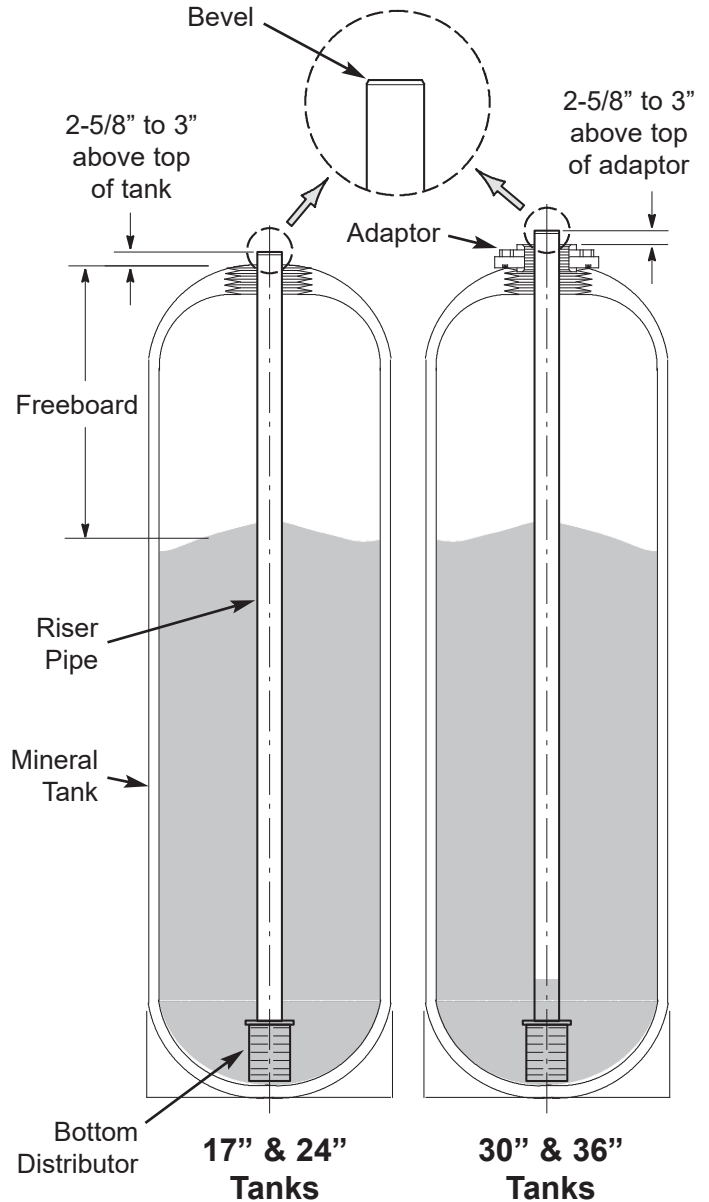

FIG. 1

Note: Resin tank height can vary somewhat within manufacturing tolerance. So to be sure the bottom distributor riser pipe has proper clearance with inside valve porting, check for the correct length, as shown above. Cut the riser if needed to adjust the length. Be sure to remove burrs and sharp edges.

from the distributor tube and apply a light coat of lubricating grease to the top edge of the tube.

9. Finish filling the tank with water, up to the top of the tank.

Important: Be sure to fill with water. This will eliminate air space and prevent excessive air-head pressure when the water conditioner is pressurized.

continued on next page

ASSEMBLY

10. From the parts box, obtain the tank adaptor and a 4-1/2" O.D. o-ring seal. Lubricate the o-ring and place in the groove at the bottom of the tank adaptor (Figure 2).

11. Lower the tank adaptor over the bottom distributor and onto the tank. Turn the adaptor clockwise to screw it into the tank top opening, being careful not to cross-thread. Tighten (use a strap wrench or large pipe wrench) until the adaptor just makes contact with the tank top and no gap is seen. **Do not overtighten** and damage the tank threads.

12. Referring to Figure 2, do the following:

a. Place the screen (except filters) over the top distributor. Then, center the assembly over the bottom distributor riser pipe, and push down into the tank adaptor.

b. Place a lubricated 2-3/4" O.D. o-ring onto the top of the riser pipe, and a 4-1/2" O.D. o-ring on the outside bottom of the support. With the square key on the support toward the rear, lower into the tank adaptor, carefully seating into place.

c. Lubricate the 3-1/4" O.D. o-rings, and place over the elongated ports on the top of the support.

13. Lower the valve assembly onto the tank adaptor and support (Figures 2 and 3). The valve must be lowered straight down or the o-rings will slip out of place. Install the two large clamps, securing with the two retainers. **Be sure the clamps and retainers are secured in place.**

The aspirator (or aspirator plug for filters) and drain flow control nipple assemblies, needed for your model, are packed in a separate carton. The assemblies contain all of the required parts for upflow regenerated softeners on medium range water supply pressures (refer to the chart on page 10). See step 16 to install.

When installing a softening system on low or high water pressures, and all downflow regeneration applications (specified when sizing and ordering) different nozzle / venturi / pre-nozzle flow plug combinations are needed. The parts required to control brine and rinse rates for your particular application are included in a separate parts bag so you can convert the aspirator (Figure 4).

14. Using 3-1/4" O.D. o-rings, clamps and retainers, install 2" nipples in the inlet and outlet valve ports (Figure 3). **Be sure the clamps and retainers are secured in place.**

15. Using 3-1/4" O.D. o-ring, clamps and retainers, install the factory assembled (with flow controls) drain nipple in the valve outlet port (Figure 3). **Be sure the clamps and retainers are secured in place.**

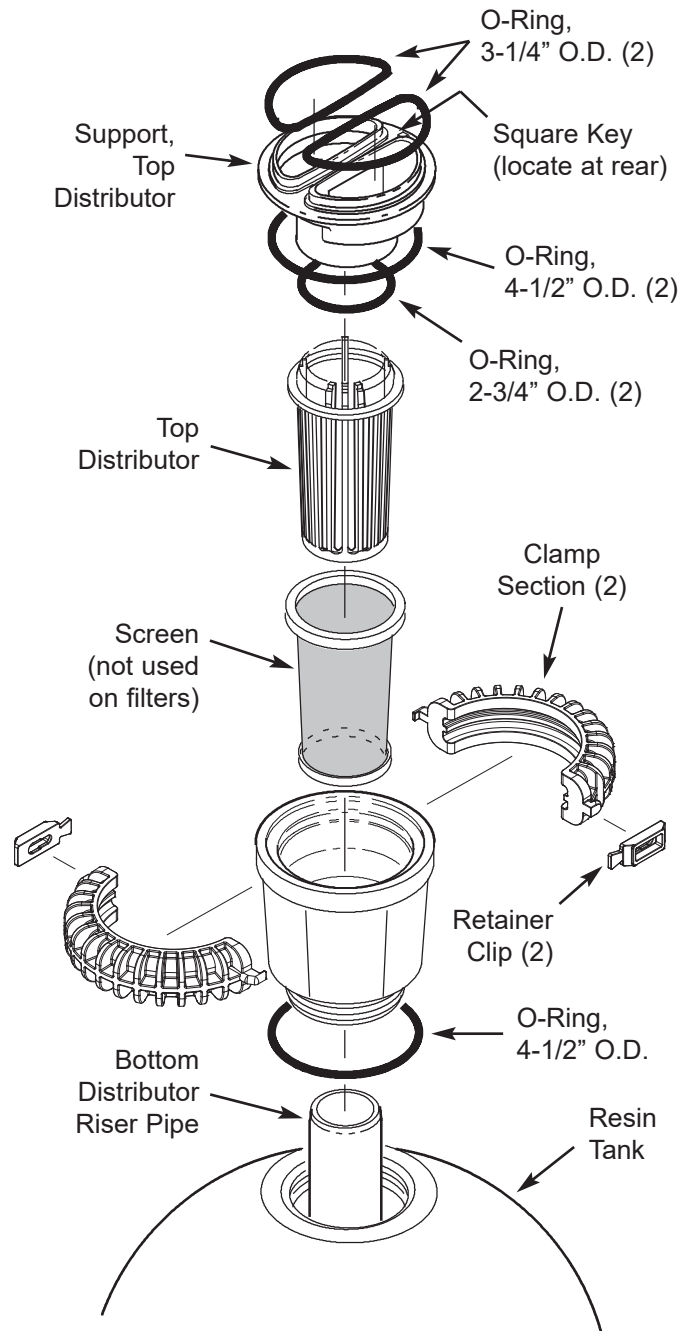

FIG. 2

16. Softeners only: The aspirator assembly has all of the required components to control brine and rinse rates for upflow regeneration applications at medium water pressures (shaded rows in following chart). If these conditions apply to this installation, do step a below. Refer to Figures 4 and 5, page 9.

If the system is installed on low or high water pressures, and all downflow regeneration applications, (specified when sizing and ordering) the parts required

continued on page 10

ASSEMBLY

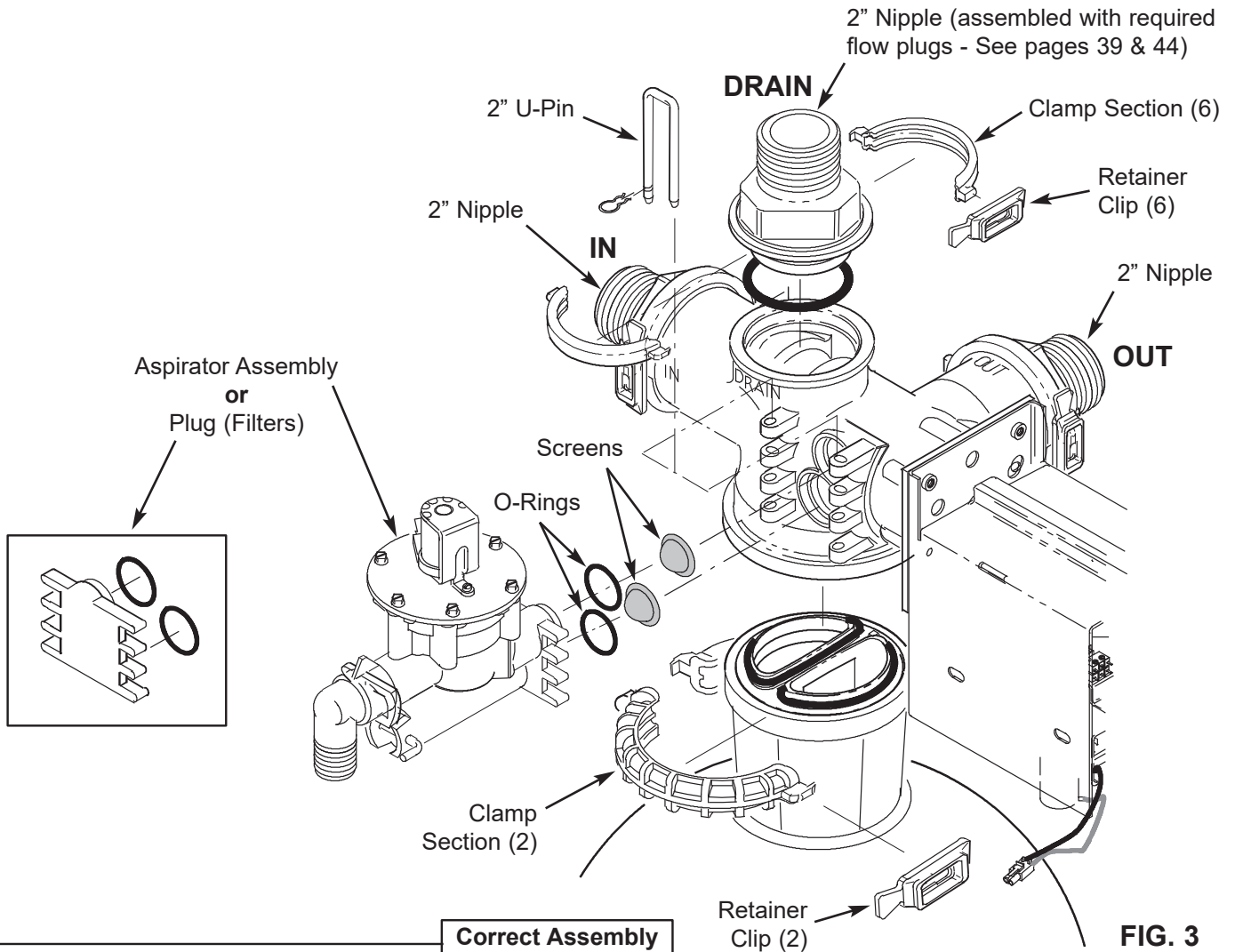

INSTALLING NOZZLE, VENTURI & PRE-NOZZLE FLOW PLUG

(If required- See chart on page 10)

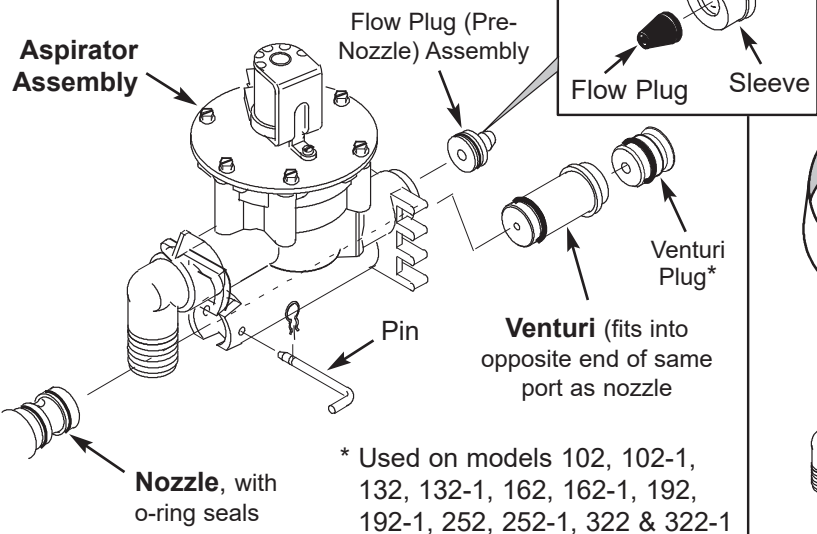

* Used on models 102, 102-1, 132, 132-1, 162, 162-1, 192, 192-1, 252, 252-1, 322 & 322-1

ASPIRATOR ASSEMBLY LOCATION FOR DOWNFLOW REGENERATION

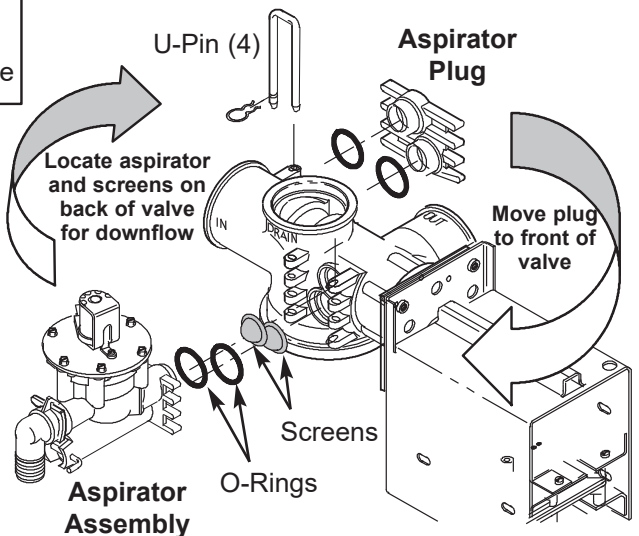

ASSEMBLY

16. Softeners only (continued)

to control brine and rinse rates for your particular application are included in a separate parts bag so you can convert the aspirator. Do following step b.

a. Install the aspirator, as factory assembled, on the front of the valve. Be sure to use screens and o-ring seals. Secure in place with two u-pins.

b. Convert the aspirator assembly following the chart below. Then, for upflow regeneration, install the aspirator using step a. For downflow regeneration, do following step c.

Notes (see Figure 4): To remove the nozzle and/or venturi, use a common screwdriver in the pry slots provided. Be sure to face the small end of the pre-nozzle flow plug toward the 2" valve. Be sure to transfer the venturi plug, used on specified models.

c. After converting the aspirator, remove the plug on the back side of the valve and install the aspirator, see Figure 5. Be sure to use screens and o-ring seals.

Secure in place with two u-pins. Move the plug to the front of the valve and install using o-rings and u-pins.

17. Filters only: Install the aspirator plug on the front of the valve. Be sure to use the o-ring seals. Secure in place with two u-pins.

18. Multiple units: All valves are shipped with an open piston. As in single units, water flows during regeneration directly to the outlet side of the valve without passing through the resin tank. If a particular installation requires 24 hour soft water, normally open diaphragm valves should be installed to prevent hard water to the facility during regeneration. These are available as optional parts (see accessories listed in the back of this manual). Installation instructions, included electrical connections, are provided with the diaphragm valve. The 24V DC required to operate the diaphragm valve is available from the pair of white wires on the controller cable (see wiring connection diagram). This voltage closes the diaphragm valve during Brine, Backwash and Fast Rinse positions.

MODEL	Regeneration Water Flow	System Water Pressure (PSI)	Aspirator Assembly Parts Conversions Required	
			Nozzle / Venturi (pull clip and pin)	Pre-Nozzle Flow Plug
102, 102-1, 132, 132-1, 162, 162-1	UP flow	Low (30 - 55)	Use as assembled (purple)	Remove - not used
		Med. (40 - 85)	Use as assembled (purple)	Use as assembled (blue)
		High (65 - 125)	Change to green	Change to light blue
	DOWN flow	Low (30 - 45)	Change to black	Remove - not used
		Med. (45 - 95)	Change to red	Remove - not used
		High (60 - 125)	Change to gray	Remove - not used
192, 192-1, 252, 252-1, 322, 322-1	UP flow	Low (30 - 65)	Change to red	Install sleeve, with green flow plug
		Med. (35 - 80)	Use as assembled (gray)	Use as assembled (none used)
		High (45 - 125)	Change to red	Install sleeve, with orange flow plug
	DOWN flow	Low (30 - 55)	Change to yellow	Use as assembled (none used)
		Med. (40 - 125)	Change to black	Use as assembled (none used)
		High (95 - 125)	Change to red	Use as assembled (none used)
362, 452	UP flow	Low (30 - 50)	Change to black	Remove - not used
		Med. (35 - 90)	Use as assembled (red)	Use as assembled (yellow)
		High (55 - 125)	Change to gray	Remove - not used
	DOWN flow	Low (30 - 45)	Change to orange	Remove - not used
		Med. (45 - 80)	Change to blue	Remove - not used
		High (85 - 125)	Change to yellow	Remove - not used
602	UP flow	Low (30 - 50)	Change to yellow	Use as assembled (none used)
		Med. (35 - 105)	Use as assembled (black)	Use as assembled (none used)
		High (45 - 125)	Change to red	Use as assembled (none used)
	DOWN flow	Low (30 - 45)	Change to white	Use as assembled (none used)
		Med. (45 - 80)	Change to orange	Use as assembled (none used)
		High (85 - 125)	Change to blue	Use as assembled (none used)

ASSEMBLY

If an application requires diaphragm valves, we recommend installing on the outlet of each unit. Some unique applications may warrant installations on the inlet. A diaphragm valve should be separated from the water meter by at least a 2" nipple and coupling. This helps assure water meter accuracy.

Note: Diaphragm valves ship with a short length of tubing on the solenoid. After regeneration finishes, this tubing vents the water used to close the valve during regeneration. Although only a very small amount of water spits out this line at the conclusion of regeneration, in "clean" installations, it may be desirable to run a longer section of tubing to drain.

IDENTIFICATION OF NOZZLE & VENTURI PARTS

Nozzle and venturi parts are molded of gray plastic, with two means of identification:

- A letter stamped into one end of the part, as shown below.
- A colored dot painted onto the part, where shown below.

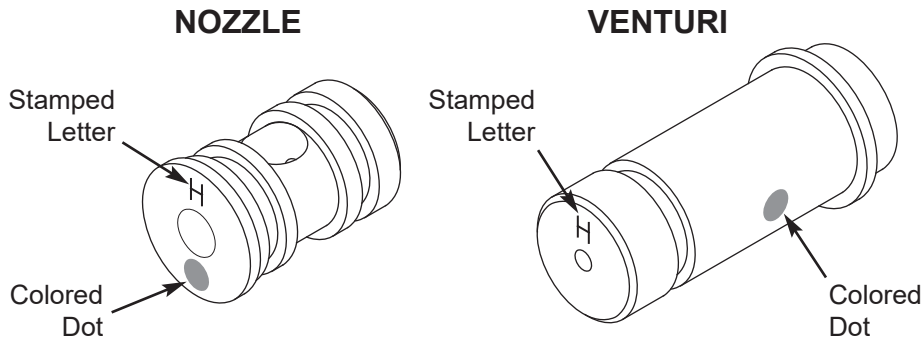

Stamped Letter	Colored Dot
A	Green
B	Purple
C	Gray
D	Red
F	Black
G	Yellow
H	Blue
J	Orange
K	White
M	Green

TYPICAL INSTALLATION PLUMBING (SOLDERED COPPER OR CPVC PLASTIC SHOWN)

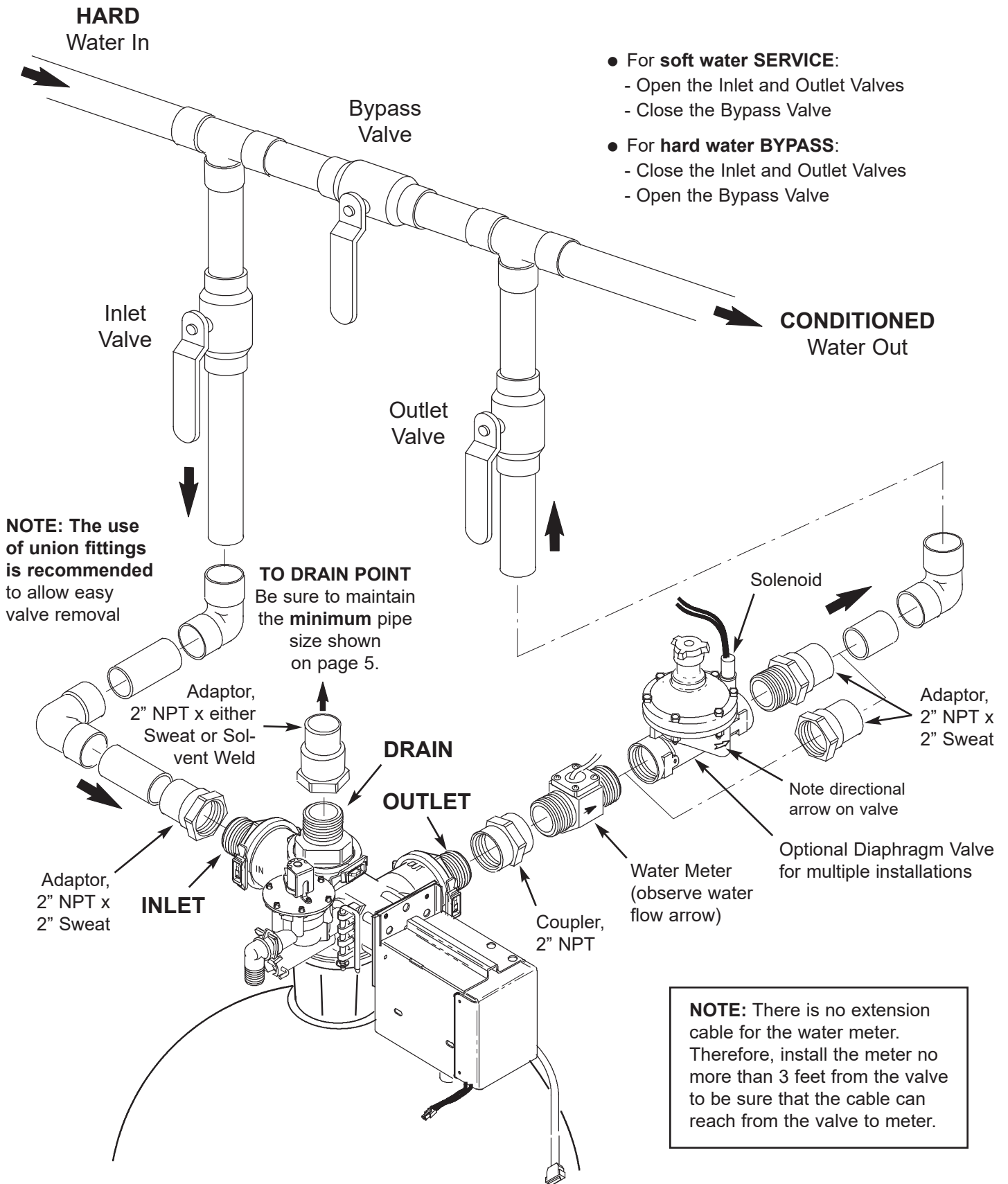

INSTALLATION NOTES

NOTES AND CAUTIONS WHEN MAKING IN AND OUT PLUMBING CONNECTIONS:

- **Be sure to close the main water supply valve to turn off the water.**
- **CAUTION:** When soldering, make subassemblies of the inlet, outlet and drain plumbing. Solder the subassemblies and allow to cool before turning them onto the valve fittings. **Soldering heat will damage the valve adaptor fittings.**
Example: Looking at page 12, make soldered subassemblies of the 2" NPT x 2" sweat adaptors and a length of pipe. Allow to cool before turning onto the valve fittings. Then, wrap wet rags around the subassemblies when making other solder joints nearby the valve.
- **Install a 3-valve bypass system, as shown on page 12.** Bypass valves allow you to direct water through the softener or filter, or to bypass it if needed.
- For multiple tank units, plumb a reverse return header (see Figure 6) to assure equal flows in each tank.
- **Use union fittings** to enable easy disconnection and maintenance of the valve and resin tank, if needed.
- **Use Teflon tape or pipe joint compound** on all outside pipe threads.
- If needed, **lubricate o-ring seals** with high quality silicone grease.
- Be sure to plumb so hard/untreated water is directed to the valve **inlet**.
- **Support all plumbing** in an acceptable manner (pipe hangers, strapping, etc.) to keep the weight off of the valve.

INSTALLATION STEPS

TYPICAL MULTIPLE UNIT INSTALLATION

Make plumbing to and from both units identical.

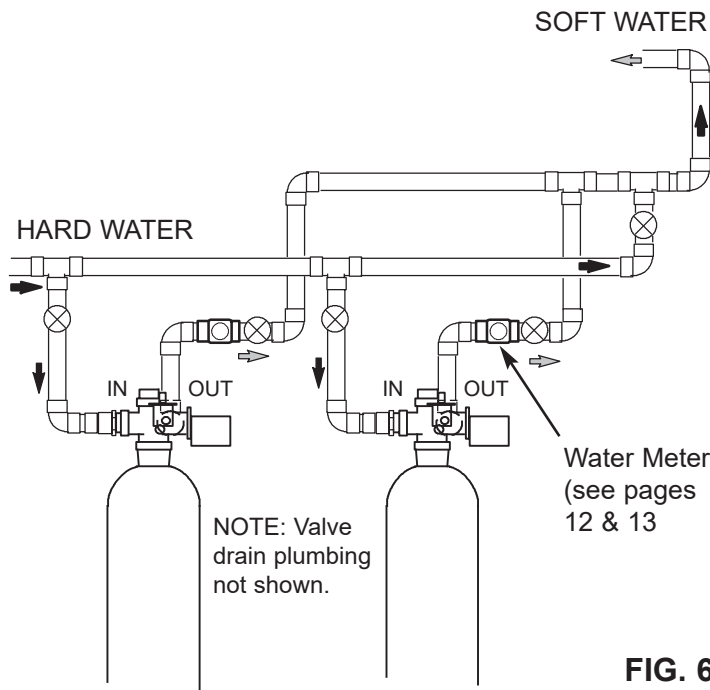

FIG. 6

NOTE FOR MULTIPLE TANK INSTALLATIONS:

To promote equal water flow, make the inlet and outlet plumbing configuration to each valve as identical as possible (see Figure 6). Use the same fittings and pipe lengths for the connection of each unit, or use a reverse return header.

1. Referring to the typical installation drawing on page 12, plumb the main water supply to the valve inlet adaptor (valve is marked IN). Be sure to observe all notes and cautions above.

2. Route plumbing from the valve outlet (marked OUT), back to the main water supply pipe. Be sure to install the water meter **horizontally** or **vertically downward** only (will not work accurately with flow arrow pointing upward), and to observe the water flow direction arrow. For ease of installation, remove meter assembly from housing until all plumbing connections are complete. When reassembling, observe that the directional arrows are properly aligned.

3. Route a pipe from valve DRAIN fitting to the drain point. Be sure the drain pipe is no less than the recommended minimum diameter (see page 5) along the entire length. A restriction, causing back-pressure, may prevent proper operation of the conditioner. Observe the following:

- Be sure the floor drain (or other acceptable drain - observe local codes) is capable of carrying away the backwash flows listed in the specifications.
- Provide an air gap between the end of the drain pipe and the drain point. The air gap prevents possible siphoning of sewer water if the drain backs up.
- Keep the drain line as short as possible and with a minimum of bends, etc. to promote good flow.
- Easy access to the drain point is desirable to check regeneration cycle flow rates.
- On multiple tank systems, drain lines of the same size can be teed together to the drain point.

INSTALLATION STEPS

4. Move the brine tank (water softener only) into position nearby the resin tank, setting on a flat, smooth surface. Do not set on protrusions or uneven surfaces that could cause the tank to puncture or break. If assembly is needed, place the brine valve (or air check) in the brinewell and put both into the brine tank. Insert brine valve top elbow out the hole in the brine tank sidewall. Install the 3/4" x 1/2" reducer (Figure 7).

5. **CONNECT BRINE TUBING:** Install the coupler and tubing connector fittings at the brine elbow (Figure 7), and a tubing connector at the brine valve. Connect a length of 1/2" O.D. tubing between the fittings, routing out of the way, and without sharp bends or kinks.

NOTE: If a multiple tank installation, use the 1/2" nipple and tee fitting to make connections to both valve drain elbows (see below).

6. **BRINE TANK OVERFLOW HOSE:** Install a length of 5/8" I.D. garden hose to the brine tank overflow elbow fitting. Place the outlet of the hose over the floor drain.

NOTE: This is a gravity drain. **Do not** elevate the hose higher than the elbow fitting in the tank sidewall.

7. **PRESSURE TESTING:** **To prevent excessive air pressure in the conditioner tank, do the following steps in exact order.** For multiple tank systems, purge air from each tank individually.

CAUTION: If you did not fill the conditioner tank with water in step 9, page 7, first complete steps 9 through 12. Then, using the RECHARGE button, and observing the decal on the bottom of the valve drive, cycle the valve into "Backwash" (#7) position. Press the RECHARGE button once, move the cursor (>) to **Recharge Now** and press the MENU/EXIT (←) button. Use the DOWN (▼) button to move the cursor (>) to **Tank #1** and press the RECHARGE button once to advance to each position, until you reach Backwash. Complete the following pressure testing steps.

- Fully open two or more conditioned cold water faucets nearby the conditioner.
- Place the plumbing bypass valves in hard water "Bypass" position (see page 12). Close the inlet and outlet valves, and then open the bypass valve.
- Fully open the main water supply valve. Observe steady flow from the opened faucets, with no air bubbles.
- **EXACTLY** as follows, place bypass valves into soft water "Service" position: **SLOWLY** open the inlet valve, pausing several times to allow the unit to pressurize slowly. (If you cycled the valve into backwash, water will flow from the drain.) Open the outlet valve and close the bypass valve.
- **After about 3 minutes, open a hot water faucet** for about one minute, or until all air is expelled. Then

1/2" BRINE TUBING CONNECTION

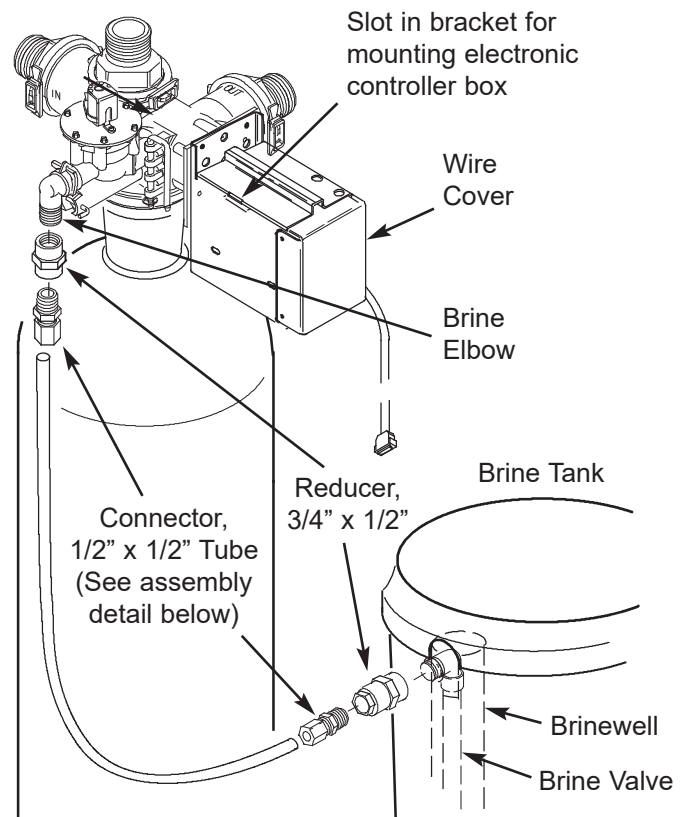

BRINE TUBING CONNECTION, MULTIPLE TANK SYSTEM

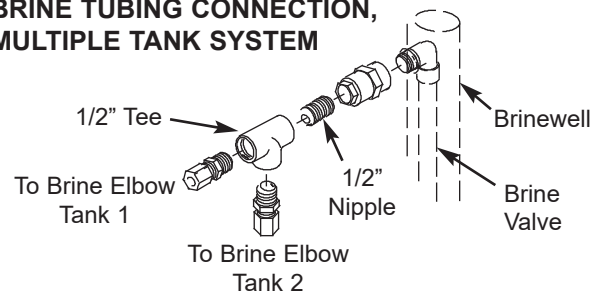

CONNECTOR ASSEMBLY DETAIL

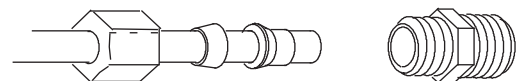

FIG. 7

close it. (If you cycled the valve into backwash, use the RECHARGE button to return the valve to "Service").

- **Close all cold water faucets** and check your plumbing work for leaks. Repair any leak before continuing.

continued on next page

INSTALLATION STEPS

8. ADD WATER AND SALT TO THE BRINE TANK: Add about 1-1/2" to 2" of water into the brine tank. Then, fill with clean water softener salt. The recommended nugget, pellet and coarse solar salts have **less than 1% impurities**. Salt storage capacities are shown in the table on page 4.

9. A soldered copper 3-valve bypass, as shown on page 12, maintains **cold water pipe ground continuity**. If your installation breaks continuity (plastic pipe, dielectric fittings, etc.), provide a jumper wire across the removed section of metal pipe. Securely clamp the wire on both ends, making sure good contact is made between the wire and pipe.

10. MOUNT THE ELECTRONIC CONTROL BOX on the front of the valve motor box (Figure 7) or in a convenient location nearby the conditioner(s), and within reach of water meter and power cord connections.

11. CONNECT LEADWIRES: Referring to the diagram on the next page, connect electrical leadwires as follows.

NOTE: The power supply must be unplugged from line power before connecting or disconnecting controller cables. If not, it may result in damage to controller circuits.

- Line power cord to power supply ①
- Power cable from power supply to electronic box ②
- Controller cable to electronic box ③

NOTE: For multiple tank installation, only one power supply is required for up to four tanks.

12. PLUG POWER SUPPLY INTO A 120V, 60 Hz ELECTRICAL OUTLET.

13. DO THE STARTUP PROGRAMMING: Upon installation, all controller settings are required. Follow procedures on pages 17 through 20.

NOTE: Multiple units require only one power supply

WIRING CONNECTION DIAGRAM

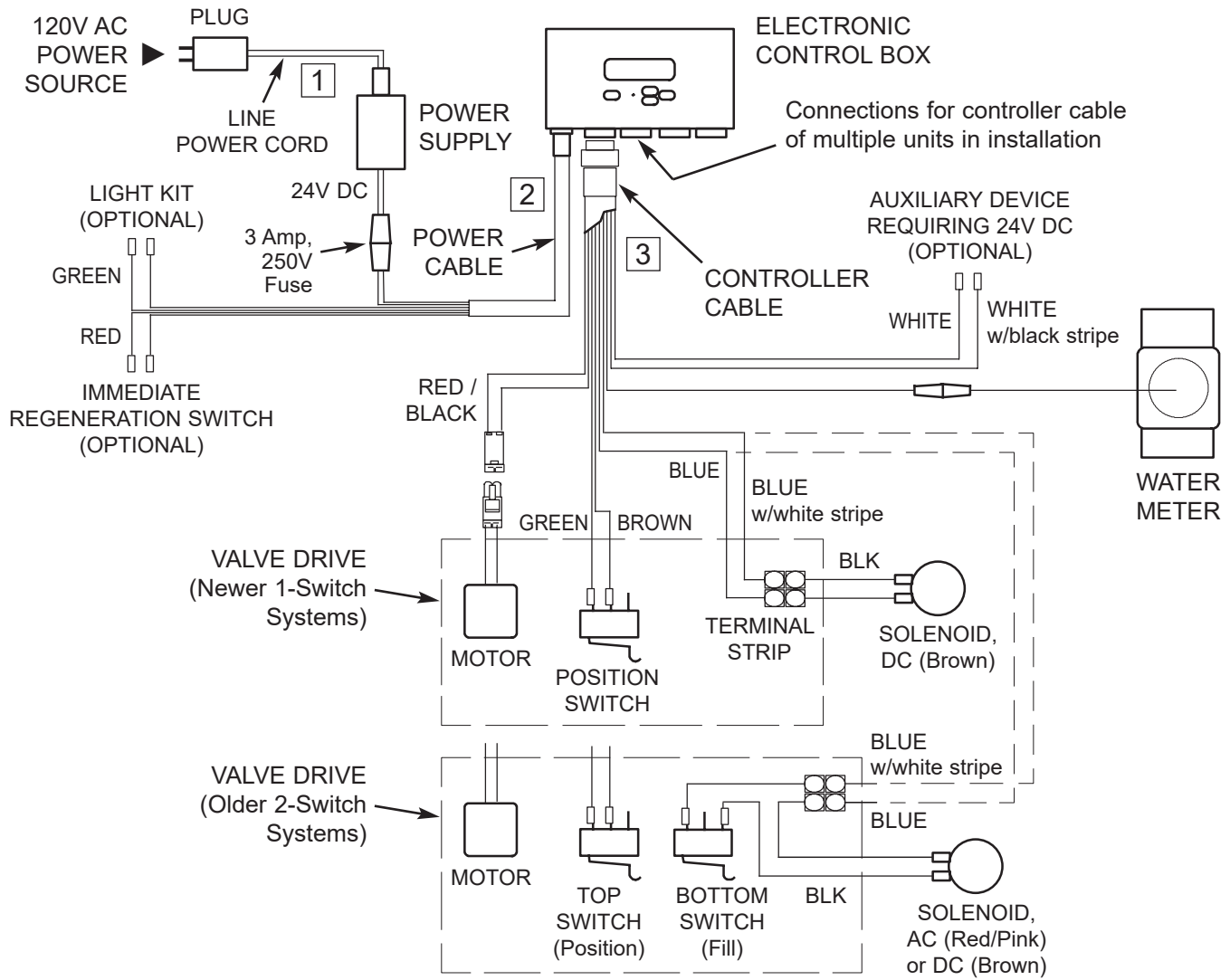

Newer 1-Switch Systems

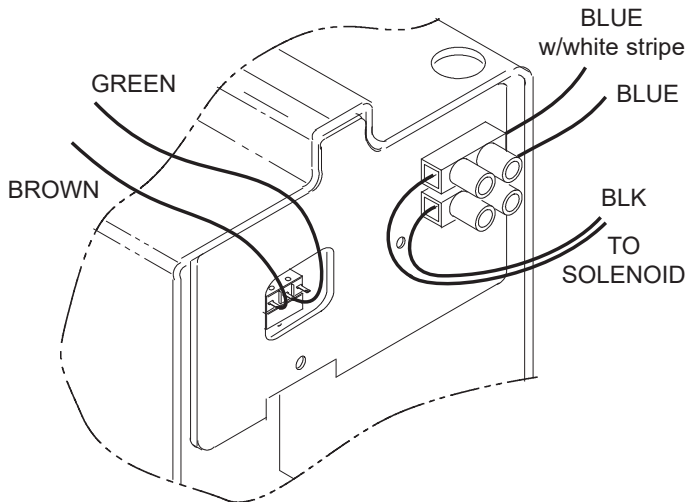

Older 2-Switch Systems

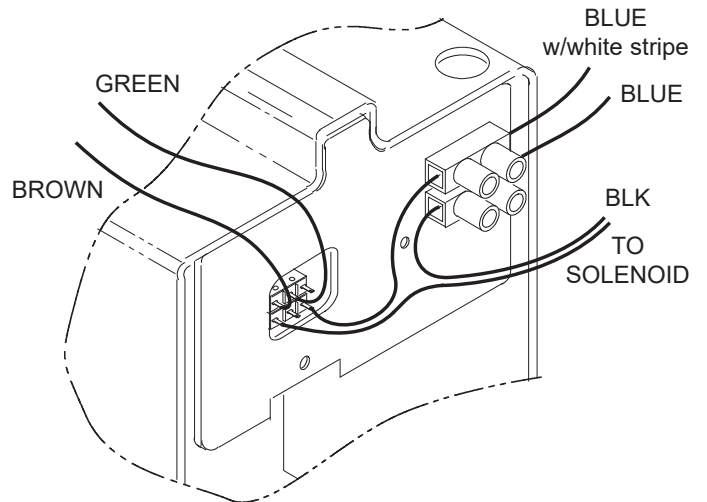

PROGRAMMING THE ELECTRONIC CONTROLLER AT STARTUP

(Once programmed, see page 22 to reset time / recharge, see pages 23-26 for other settings)

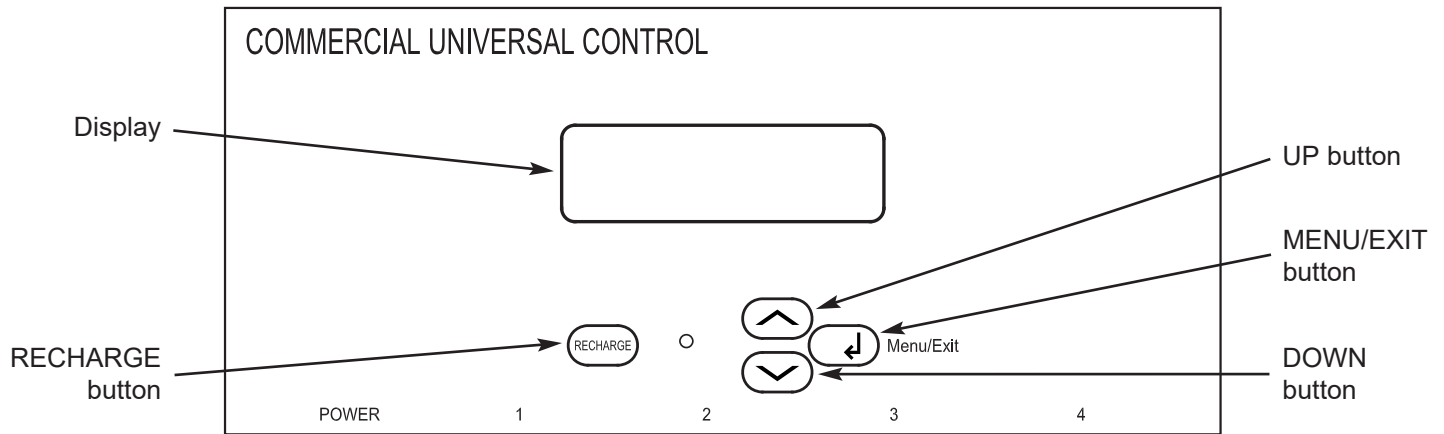

The CUC2 is a menu-driven electronic controller with a dot matrix display. The UP (▲) and DOWN (▼) buttons move the cursor (>) up and down the menu choices. The MENU/EXIT (←) button enters the value selected and returns the display back a level. The controller will return to the normal operating screen after 4 minutes, if left in a menu and no selection has been made.

A “beeper” sounds when controller buttons are pressed. One beep signals a change in the faceplate display. Repeated beeping means the controller will not accept a change from the button you have pressed, telling you to use another button.

```
-----
Version : C5.0
```

When the power supply is first plugged in, a screen is displayed for approximately 8 seconds showing the software version, then the following screens are displayed to program the controller.

```
> English
  Español
  Français
↑↓ Change   ← Exit
```

1. SET LANGUAGE: Using the UP (▲) or DOWN (▼) buttons, move the cursor (>) next to the preferred language. Press the MENU/EXIT (←) button to select and advance to the next setting.

```
Set English/Metric :
English
↑↓ Change           ← Exit
```

2. SET ENGLISH/METRIC: Using the UP (▲) or DOWN (▼) buttons, set the controller to measure in either English or Metric units. Press the MENU/EXIT (←) button to select and advance to the next setting.

```
Set 12/24 Hour
Clock :
12 Hour
↑↓ Change       ← Exit
```

3. 12/24 HOUR CLOCK: Using the UP (▲) or DOWN (▼) buttons, set the time format to either a 12 or 24 hour clock. Press the MENU/EXIT (←) button to select and advance to the next setting.

```
Set Valve
Type :
2" Up - Gray
↑↓ Change       ← Next
```

4. SET VALVE TYPE: Use the UP (▲) or DOWN (▼) buttons to display the valve type (2 inch upflow or downflow, blue or gray turbine - older production used blue, newer units have gray). When the correct valve type for the application is shown, press the MENU/EXIT (←) button to select and advance to the next setting.

```
Set Number of
Valves :
Quadplex
↑↓ Change       ← Next
```

5. SET NUMBER OF VALVES: If one softener or filter is installed, set Simplex in the display using the UP (▲) or DOWN (▼) buttons, then press the MENU/EXIT (←) button to select and advance to the next setting. If multiple units are installed, set Duplex, Triplex or Quadplex, as appropriate for the installation.

PROGRAMMING THE ELECTRONIC CONTROLLER AT STARTUP

```
Set Recharge
Method:
Parallel Delayed
↑↓ Change      ← Next
```

6. SET RECHARGE METHOD (for multiple tank applications only): There are four choices for recharge method:

- When **Peak Flow** (see step 17) is selected, each tank recharges as capacity is used.
- **Alt. Immediate** initiates an immediate recharge on a tank as capacity is used. When that tank is finished recharging it is put into standby mode.
- **Parallel Immediate** recharges each tank in sequence immediately as capacity is used.
- **Parallel Delayed** recharges each tank in sequence at the scheduled recharge time.

Using the UP (▲) or DOWN (▼) buttons, select recharge method and press the MENU/EXIT (←) button to select and advance to the next setting.

```
Set System
Type:
Softener
↑↓ Change      ← Next
```

7. SET SYSTEM TYPE: Using the UP (▲) or DOWN (▼) buttons, select either softener or filter system type, then press the MENU/EXIT (←) button to select and advance to the next setting.

SOFTENERS ONLY (go to Page 20 for filters)

```
Set Resin
Qty:
3.0 Cubic Feet
↑↓ Change      ← Next
```

8. SET RESIN QUANTITY: Using the UP (▲) or DOWN (▼) buttons, select the amount of resin, in increments of .5 cubic feet (per tank), that will be used in the system. Press the MENU/EXIT (←) button to select and advance to the next setting.

```
Set Refill
Rate:
1.0 gpm
↑↓ Change      ← Next
```

9. SET REFILL RATE: Using the UP (▲) or DOWN (▼) buttons, select the refill rate to the suggested gallons per minute flow rate table in your manual. Press the MENU/EXIT (←) button to select and advance to the next setting.

```
Set Efficiency Mode:
Actual Dose
↑↓ Change      ← Next
```

10. SET EFFICIENCY MODE: Using the UP (▲) or DOWN (▼) buttons, select the salt efficiency mode:

- **Salt Efficient** will provide a salt efficiency of 4,000 grains or higher.
- **Boiler Option** will have 1 ppm soft water bleed or less.
- **Auto Adjusting** adjusts itself among 5 operating capacities, based on frequency of regenerations.
- **Actual Dose** allows the user to set actual salt dose in lbs/cu. ft. If Actual Dose is selected, the controller will continue to a Set Salt Dose screen.

```
Set Salt
Dose:
12 lb per ft3
↑↓ Change      ← Next
```

Press the MENU/EXIT (←) button to select and advance to the next setting.

NOTE: If Auto Adjusting is chosen, brine times will still need to be selected in Step 12.

```
Set Fixed Reserve:
Automatic
↑↓ Change      ← Next
```

11. SET FIXED RESERVE (Simplex or Parallel Delayed Systems only; only if Actual Dose is selected in Step 10): If a minimum capacity must be available on any given day, use the UP (▲) or DOWN (▼) buttons to select the percentage of operating capacity required. See the table in your manual to determine actual capacity available. If **Automatic** is selected, the fixed reserve percentage will vary, based on a weekly average of capacity used. Press the MENU/EXIT (←) button to select and advance to the next setting.

```
Set Brine
Time:
180 Minutes
↑↓ Change      ← Next
```

12. SET BRINE TIME: Using the UP (▲) or DOWN (▼) buttons, select the brine time to the suggested minutes from the table on page 21. Press the MENU/EXIT (←) button to select and advance to the next setting.

```
Set Backwash
Time:
15 Minutes
↑↓ Change      ← Next
```

13. SET BACKWASH TIME: Using the UP (▲) or DOWN (▼) buttons, select the backwash time to the suggested minutes from the table on page 21. Press the MENU/EXIT (←) button to select and advance to the next setting.

PROGRAMMING THE ELECTRONIC CONTROLLER AT STARTUP - SOFTENERS

```
Set Fast Rinse
Time :
  5 Minutes
↑↓ Change      ← Next
```

14. SET FAST RINSE TIME: Using the UP (▲) or DOWN (▼) buttons, select the fast rinse time to the suggested minutes from the table on page 21. Press the MENU/EXIT (←) button to select and advance to the next setting.

```
Set Salt
Monitor Feature :
Off
↑↓ Change      ← Next
```

15. SET SALT MONITOR FEATURE: Using the UP (▲) or DOWN (▼) buttons, display ON or OFF. If ON is selected, you must also enter the diameter of the brine tank. If this is a multiple valve application, and ON is selected, the number of Valves Per Brine Tank must be entered. Press the MENU/EXIT (←) button to select and advance to the next setting.

```
Set Minimum Tanks
In Service :
  3 Tanks
↑↓ Change      ← Next
```

16. SET MINIMUM TANKS IN SERVICE (Triplex and Quadplex units only): Using the UP (▲) or DOWN (▼) buttons, display the minimum number of tanks that are needed to be in service at a time. Press the MENU/EXIT (←) button to select and advance to the next setting.

```
Peak Flow
Trippoint :
  0.0 gpm
↑↓ Change      ← Next
```

17. SET PEAK FLOW TRIP POINT: If Peak Flow was selected as the method of recharge in Step 6, this option is activated. Using the UP (▲) or DOWN (▼) buttons, select the flow rate (1.0 gallons per minute minimum to 750 gpm maximum) at which you will **temporarily** require another unit to come into service. The unit will come online when the flow rate reaches this trip point. The unit will return to standby when a minimum of 30 minutes has elapsed **and** the flow rate falls below the trip point. Press the MENU/EXIT (←) button to select and advance to the next screen.

```
Softener
2UF Quadplex
-----
Version : C5.0
```

After these initial settings are completed, the display will show that the controller is being reset. The display will then show a screen with the current settings before moving to the next screen and required setting.

```
Set Clock :
12:00PM
↑↓ Change      ← Exit
```

18. SET CLOCK: Using the UP (▲) or DOWN (▼) buttons, set the present time, making sure that AM or PM is correct. By pressing and holding either the UP (▲) or DOWN (▼) button, the display will scroll at faster increments. Press the MENU/EXIT (←) button to select and advance to the next setting.

NOTE: The clock will need to be reset only if power is out for a long time.

```
Set Hardness :
  25 Grains
↑↓ Change      ← Exit
```

19. SET HARDNESS: Using the UP (▲) or DOWN (▼) buttons, set the water hardness level, from 1 to 160 grains per gallon or 10 to 2740 PPM (parts per million). By pressing and holding either the UP (▲) or DOWN (▼) button, the display will scroll at faster increments. Press the MENU/EXIT (←) button to select and advance to the next setting.

```
Set Recharge
Time :
12:00AM
↑↓ Change      ← Exit
```

20. SET RECHARGE TIME: This screen is shown only for a single valve system or if Parallel Delayed recharge setting has been selected. Using the UP (▲) or DOWN (▼) buttons, set the desired time for regenerations to start. Press the MENU/EXIT (←) button to select and advance to the next screen.

```
Recharge           3:45PM
Tonight At:
12:00AM
                    ← Menu
```

The display returns to the normal he normal operating screen when programming has been completed.

The initial programming steps for softeners are complete.

PROGRAMMING THE ELECTRONIC CONTROLLER AT STARTUP - FILTERS

FILTERS ONLY

```
Set Filter  
Capacity:  
Off  
↑↓ Change      ← Next
```

21. SET FILTER CAPACITY: Using the UP (▲) or DOWN (▼) buttons, select the number of gallons, in 1000 gallon increments, at which you want the filter to backwash. If **OFF** is selected, the filter will not backwash automatically, and it must be initiated manually. Press the MENU/EXIT (←) button to select and advance to the next setting.

```
Set Fixed  
Reserve:  
Automatic  
↑↓ Change      ← Next
```

22. SET FIXED RESERVE (Simplex or Parallel Delayed systems only): If a minimum capacity must be available on any given day, use the UP (▲) or DOWN (▼) buttons to select the percentage of filter operating capacity required. If **Automatic** is selected, the fixed reserve percentage varies, based on a weekly average of capacity used. Press the MENU/EXIT (←) button to select and advance to the next setting.

```
Set Backwash  
Time:  
15 Minutes  
↑↓ Change      ← Next
```

23. SET BACKWASH TIME: Using the UP (▲) or DOWN (▼) buttons, select backwash time from 1 minute minimum to 30 minutes maximum. The minimum recommended time for filters is about 15 minutes. Increase the time as needed to thoroughly clean the filter bed. Press the MENU/EXIT (←) button to select and advance to the next setting.

```
Set Fast Rinse  
Time:  
5 Minutes  
↑↓ Change      ← Next
```

24. SET FAST RINSE TIME: Using the UP (▲) or DOWN (▼) buttons, select fast rinse time from 1 minute minimum to 30 minutes maximum. The factory setting of 5 minutes is usually adequate. Press the MENU/EXIT (←) button to select and advance to the next setting.

```
Set Minimum Tanks  
In Service:  
3 Tanks  
↑↓ Change      ← Next
```

25. SET MINIMUM TANKS IN SERVICE (Triplex and Quadplex units only): Using the UP (▲) or DOWN (▼) buttons, display the minimum number of tanks that are needed to be in service at a time. Press the MENU/EXIT (←) button to select and advance to the next setting.

```
Peak Flow  
Trippoint:  
0.0 gpm  
↑↓ Change      ← Next
```

26. SET PEAK FLOW TRIP POINT: If Peak Flow was selected as the method of recharge in Step 6, this option is activated. Using the UP (▲) or DOWN (▼) buttons, select the flow rate (1.0 gallons per minute minimum to 750 gpm maximum) at which you will **temporarily** require another unit to come into service. The unit will come online when the flow rate reaches this trip point. The unit will return to standby when a minimum of 30 minutes has elapsed **and** the flow rate falls below the trip point. Press the MENU/EXIT (←) button to select and advance to the next screen.

```
Filter  
2UF Quadplex  
-----  
Version : C5.0
```

After these initial settings are completed, the display will show that the controller is being reset. The display will then show a screen with the current settings before moving to the next screen and required setting.

```
Set Clock:  
12:00PM  
↑↓ Change      ← Exit
```

27. SET CLOCK: Using the UP (▲) or DOWN (▼) buttons, set the present time, making sure that AM or PM is correct. By pressing and holding either the UP (▲) or DOWN (▼) button, the display will scroll at faster increments. Press the MENU/EXIT (←) button to select and advance to the next setting.

NOTE: The clock will need to be reset only if power is out for a long time.

```
Set Recharge  
Time:  
12:00AM  
↑↓ Change      ← Exit
```

28. SET RECHARGE TIME (Simplex or Parallel Delayed systems only): Using the UP (▲) or DOWN (▼) buttons, set the desired time for regenerations to start. Press the MENU/EXIT (←) button to select and advance to the next screen.

```
Water          3:45PM  
Flow Rate:  
2.0 gpm  
← Menu
```

The display returns to the normal he normal operating screen when programming has been completed.

The initial programming steps for filters are complete.

WATER SOFTENER CONTROLLER SETUP INFORMATION

MODEL	Resin Quantity (cu. ft.)	Fill Rate (gpm)	Salt Dosage (lbs./cu. ft. of resin)	Grains Capacity (upflow)	Brining Minutes (upflow)	Grains Capacity (downflow)	Brining Minutes (downflow)	Back-wash Minutes	Fast Rinse Minutes
102, 102-1	3	1.0	4, Auto Adj. or Salt Eff.	54,000	115	50,000	60	12	5
			6	72,000	110	68,000			
			8	84,000	105				
			10	93,000	100	75,000			
			12	99,000	95				
132, 132-1	4	1.0	4, Auto Adj. or Salt Eff.	72,000	150	67,000	70	12	5
			6	96,000	145	91,000			
			8	112,000	135				
			10	124,000	130	100,000			
			12	132,000	125				
162, 162-1	5	1.0	4, Auto Adj. or Salt Eff.	90,000	180	84,000	60	12	5
			6	120,000	175	114,000			
			8	140,000	170				
			10	155,000	160	125,000			
			12	165,000	150				
192, 192-1	6	2.0	4, Auto Adj. or Salt Eff.	108,000	110	100,000	60	14	10
			6	144,000	105	137,000			
			8	168,000	100				
			10	186,000	95	150,000			
			12	198,000	80				
252, 252-1	8	2.0	4, Auto Adj. or Salt Eff.	144,000	145	134,000	70	14	10
			6	192,000	140	182,000			
			8	224,000	130				
			10	248,000	125	200,000			
			12	264,000	120				
322, 322-1	10	2.0	4, Auto Adj. or Salt Eff.	180,000	180	168,000	80	14	10
			6	240,000	175	228,000			
			8	280,000	170				
			10	310,000	160	250,000			
			12	330,000	150				
362	12	3.0	4, Auto Adj. or Salt Eff.	216,000	140	202,000	70	15	12
			6	288,000	130	274,000			
			8	336,000	125				
			10	372,000	120	300,000			
			12	396,000	115				
452	15	3.0	4, Auto Adj. or Salt Eff.	270,000	175	252,000	80	15	12
			6	360,000	165	342,000			
			8	420,000	155				
			10	465,000	150	375,000			
			12	495,000	140				
602	20	3.5	4, Auto Adj. or Salt Eff.	360,000	160	336,000	70	15	12
			6	480,000	150	456,000			
			8	560,000	145				
			10	620,000	135	500,000			
			12	660,000	130				

ELECTRONIC CONTROLLER - RESETTING TIME / RECHARGE

RESETTING TIME

To set the time if incorrect, or if the display is flashing after a long power outage (when power is lost, all other settings are maintained by the computer and do not require setting):

1. Press the MENU/EXIT (↵) button to enter the Primary Menu. Using the DOWN (▼) button, move the cursor (>) to **Set Clock** and press (↵) to enter this menu.

```
EXIT
Set Salt Level
>Set Clock
Set Hardness
```

2. Using the UP (▲) or DOWN (▼) buttons, set the present time, making sure that AM or PM is correct. By pressing and holding either the UP (▲) or DOWN (▼) button, the display will scroll at faster increments.

```
Set Clock

3:45 PM
↑↓ Change      ↵ Exit
```

3. When the correct time shows, press the MENU/EXIT (↵) button to select and return to the primary menu. Using the UP (▲) button, move the cursor (>) to **EXIT** and press the MENU/EXIT (↵) button to return to the normal operating screen.

```
Water           3:45 PM
Flow Rate:
2.0 gpm
                ↵ Menu
```

RECHARGE

By pressing the RECHARGE button, the controller enters into the recharge menu. The options are **Online/Offline**, **Recharge Now** or **Recharge Tonight**. Move the cursor (>) next to selection and press the MENU/EXIT (↵) button.

```
>EXIT
Online/Offline
Recharge Now
Recharge Tonight
```

The **Online/Offline** menu allows a specific tank to be put online or taken offline. Move the cursor (>) next to the specific tank and press the MENU/EXIT (↵) button. This will toggle between "Online" and "Offline".

In the **Recharge Now** menu, you can select one or all tanks to start an immediate recharge. Move the cursor (>) next to the specific tank and press the MENU/EXIT (↵) button. This will toggle between "Service" and "Scheduled".

In the **Recharge Tonight** menu, you can schedule a recharge or cancel a recharge tonight. Move the cursor (>) next to the specific tank and press the MENU/EXIT (↵) button. This will toggle between "Service" and "Tonight".

ELECTRONIC CONTROLLER - FEATURES & OPTIONS

PRIMARY MENU

The following is a description of the features and options in the Primary Menu. To enter the Primary Menu, press the MENU/EXIT (↵) button.

```
>EXIT
Set Salt Level
Set Clock
Set Hardness
```

Using the UP (▲) or DOWN (▼) buttons, move the cursor to the feature or option that you would like to change and press the MENU/EXIT (↵) button to enter screen. To return to the normal operating screen, move the cursor (>) to EXIT and press the MENU/EXIT (↵) button.

```
Set Salt Level:
  5
■■■■■□□□□□
↑↓ Change    ↵ Exit
```

SET SALT LEVEL (Softeners only): This screen only appears if the “Salt Monitor” feature is set to ON (Step 15). Using the UP (▲) or DOWN (▼) buttons, set the salt level number from 0 to 10. Or, pressing the DOWN (▼) button past 0 will toggle “Salt Monitor” to OFF. This number corresponds with the numbers on the brinewell that the salt level is closest to. Press the MENU/EXIT (↵) button to select and return to the Primary Menu.

```
Set Clock:
  3:45 PM
↑↓ Change    ↵ Exit
```

SET CLOCK: Use the UP (▲) or DOWN (▼) buttons to set the present time, making sure that AM or PM is correct. By pressing and holding either the UP (▲) or DOWN (▼) button, the display will scroll at faster increments. Press the MENU/EXIT (↵) button to select and return to the Primary Menu.

```
Set Hardness:
  25 Grains
↑↓ Change    ↵ Exit
```

SET HARDNESS (Softeners only): Using the UP (▲) or DOWN (▼) buttons, set the water hardness level, from 1 to 160 grains per gallon or 10 to 2740 PPM (parts per million). By pressing and holding either the UP (▲) or DOWN (▼) button, the display will scroll at faster increments. Press the MENU/EXIT (↵) button to select and return to the Primary Menu.

```
Set Recharge
Time:
12:00 AM
↑↓ Change    ↵ Exit
```

SET RECHARGE TIME (Simplex or Parallel Delayed systems only): Using the UP (▲) or DOWN (▼) buttons, set the desired time for regenerations to start. Press the MENU/EXIT (↵) button to select and return to the Primary Menu.

NOTE: If a softener and filter are both being used, no more than one unit should backwash at a time.

```
T1: 2.5 gpm
T2: 3.1 gpm
T3: 1.6 gpm
T4: 2.8 gpm    ↵ Exit
```

FLOW RATE: This screen is for viewing the flow rate, in GPM or LPM, through each individual tank, depending on the configuration (simplex, duplex, etc.). Press the MENU/EXIT (↵) button to return to the Primary Menu.

```
T1: 5 Gallons
T2: 8 Gallons
T3: 4 Gallons
T4: 6 Gallons
```

WATER USED TODAY: This screen displays the number of gallons or liters that have been used in each individual tank per 24 hour time period, depending on the configuration (simplex, duplex, etc.). Press the MENU/EXIT (↵) button to return to the Primary Menu.

```
System Average Daily
Water Use:
300 Gallons    ↵ Exit
```

AVERAGE DAILY WATER USE: This screen displays the **average** number of gallons or liters that have been used in a 24 hour time period. Press the MENU/EXIT (↵) button to return to the Primary Menu.

continued on the next page

ELECTRONIC CONTROLLER - FEATURES & OPTIONS

PRIMARY MENU (continued)

```
% Capacity
Remaining:
T1: 25 T3: 48
T2: 33 T4: 37 ← Exit
```

CAPACITY REMAINING: This screen displays the percent capacity remaining in each individual tank, depending on the configuration (simplex, duplex, etc.). Press the MENU/EXIT (←) button to return to the Primary Menu.

```
Filtering      3:45 PM
Water
                ← Menu
```

NOTE: “Capacity Remaining” is not available for filters that have “Filter Capacity” set to OFF (Step 21). Screen will show “Filtering Water”.

```
>EXIT
T1: 111719 Gallons
T2: 124816 Gallons
T3: 132329 Gallons
```

WATER TOTALIZER: This screen displays the number of gallons or liters that have flowed through each individual tank since the last time the totalizer was reset. To reset (zero) the total for a particular tank, move the cursor (>) next to the tank number and press the MENU/EXIT (←) button. Move the cursor (>) to EXIT and press the MENU/EXIT (←) button to return to the Primary Menu.

```
Set 12/24 Hour
Clock:
12 Hour
↑↓ Change      ← Exit
```

SET 12/24 HOUR CLOCK: Using the UP (▲) or DOWN (▼) buttons, set the time format to either a 12 or 24 hour clock. Press the MENU/EXIT (←) button to return to the Primary Menu.

```
Set English/Metric:
English
↑↓ Change      ← Exit
```

SET ENGLISH/METRIC: Using the UP (▲) or DOWN (▼) buttons, set the controller to measure in either English or Metric units. Press the MENU/EXIT (←) button to return to the Primary Menu.

```
Set Rolling Display
Screens:
On
↑↓ Change      ← Exit
```

SET ROLLING SCREEN: Using the UP (▲) or DOWN (▼) buttons, set this feature ON or OFF. If set to ON, the normal operating screen will scroll from “Soft Water Available”, which shows the capacity remaining in each tank, to “Water Flow Rate” and “Salt Level is Low” (if applicable). If there is a recharge scheduled, “Recharge Tonight” will also be displayed. Press the MENU/EXIT (←) button to return to the Primary Menu.

ELECTRONIC CONTROLLER - FEATURES & OPTIONS

ADVANCED/SERVICE MENU

By entering these menus, a warning screen will first be displayed. Only technicians or knowledgeable users should access these menus.

The following is a description of the features and options in the Advanced/Service Menu. To enter the Advanced/Service Menu, press the MENU/EXIT (↵) button. Using the UP (▲) or DOWN (▼) buttons, move the cursor to **Advanced/Service** and press the MENU/EXIT (↵) button.

```
Set English/Metric
Set Rolling Screen
>Advanced/Service
EXIT
```

```
WARNING: Changes
could affect unit
performance.
↑ Continue ← Cancel
```

The warning screen will show, press the UP (▲) button to continue. To return to the Primary Menu, move the cursor (>) to EXIT and press the MENU/EXIT (↵) button.

```
>English
Español
Français
↑↓ Change ← Exit
```

SET LANGUAGE: Using the UP (▲) or DOWN (▼) buttons, move the cursor (>) next to the preferred language. The choices are: English, Spanish, French, German, Italian and Dutch. Press the MENU/EXIT (↵) button to select and return to the Advanced/Service Menu.

TO SET THE SYSTEM TO YOUR NATIVE LANGUAGE IF ANOTHER LANGUAGE IS DISPLAYED:

From the run status (time of day) screen, press the MENU/EXIT (↵) button. Scroll to the bottom line of the menu. Press UP (▲) once, then press MENU/EXIT (↵). Press UP (▲) once. Press DOWN (▼) once, then press MENU/EXIT (↵). Scroll to your native language, then press MENU/EXIT (↵).

```
EXIT
>Tank 1: Online
Tank 2: Online
Tank 3: Online
```

DIAGNOSTICS: This screen is for viewing only and will show any error codes plus information on each individual tank, depending on the configuration (simplex, duplex, etc.). Move the cursor (>) next to the specific tank and press the MENU/EXIT (↵) button.

```
12:34:56PM Error0 ↑
Pos: Service 0:00
Req Pos: Service
Motor:Off Sw:Open ↓
```

Press the RECHARGE button and the valve will step through each cycle of the valve. Use the UP (▲) or DOWN (▼) buttons to view all lines of the screen. Press the MENU/EXIT (↵) button to return to the diagnostics screen, then press the MENU/EXIT (↵) button again to return to the Advanced/Service Menu.

```
Set Low Salt
Alert Level:
2
↑↓ Change ← Exit
```

SET LOW SALT ALERT (Softeners only): Use the UP (▲) or DOWN (▼) buttons to change the Alert Level on a scale of 0 to 4, corresponding to the numbers on the brinewell. When the salt level falls below this level, the controller will signal that salt needs to be added to the brine tank. Press the MENU/EXIT (↵) button to select and return to the Advanced/Service Menu.

```
Set Max Days Between
Recharges:
Automatic
↑↓ Change ← Exit
```

SET MAX DAYS BETWEEN RECHARGES: Use the UP (▲) or DOWN (▼) buttons to change Max Days Between Recharges. If Automatic is selected, the electronic controller will determine when to recharge, based on water usage. If 1 to 99 is selected, the unit will never go past that number of days set for a recharge, but could recharge before. Press the MENU/EXIT (↵) button to select and return to the Advanced/Service Menu.

continued on the next page

ELECTRONIC CONTROLLER - FEATURES & OPTIONS

ADVANCED / SERVICE MENU (continued)

```
Set 97% Recharge
Feature:
Off
↑↓ Change      ← Exit
```

SET 97% FEATURE (Simplex or Parallel Delayed systems only): Use the UP (▲) or DOWN (▼) buttons to set either OFF or ON. If ON is selected, the unit will automatically recharge when 97% of capacity has been used, at any time of the day. Press the MENU/EXIT (←) button to select and return to the Advanced / Service Menu.

```
Set Chlorine / Bypass:
Bypass
↑↓ Change      ← Exit
```

SET CHLORINE / BYPASS: This feature can be used to operate external equipment, such as a chlorine genera-

tor, with a 24V DC signal from the auxiliary output. Use the UP (▲) or DOWN (▼) buttons to set to Bypass (on during the entire recharge cycle) or Chlorine (on during Brining only). Press the MENU/EXIT (←) button to select and return to the Advanced / Service Menu.

```
Set Valve
Type:
2" Up - Gray
↑↓ Change      ← Next
```

VALVE CONFIGURATION: This option allows you to reprogram the controller. After all valve configuration selections have been made, all other settings (clock, water hardness, etc.) will need to be reset.

NOTE: The controller will also reset all counts back to zero (number of recharges, etc.), except for the number of days in service.

LOCKOUT FEATURE

This feature is available to prevent unauthorized modification of parameters that affect performance. The unit is shipped from the factory with the lockout feature off. After programming is complete, the lockout feature can be turned on to prevent changes to the following:

- Hardness
- Recharge start time
- 12/24 hour time format
- English/metric units
- Rolling screens (on/off)
- Language
- Salt level trip point
- Max days between recharges
- 97% feature (on/off)
- Chlorine/bypass
- Valve configuration
- Water totalizer (reset to 0)

To turn on the lockout feature:

From any status screen, press the MENU/EXIT (←) button to display the Primary Menu. Using the DOWN (▼) button, move the cursor to **Advanced / Service** and press the MENU/EXIT (←) button.

```
Set English / Metric
Set Rolling Screen
> Advanced / Service
EXIT
```

```
WARNING: Changes
could affect unit
performance.
↑ Continue  ← Cancel
```

```
WARNING: Changes
could affect unit
performance.
↑ Continue  ← Cancel
```

The warning screen will show. Press the RECHARGE button to toggle the padlock icon. Press the MENU/EXIT (←) button to select and return to the Primary Menu.

```
EXIT
Set Clock
Set Hardness
Set Recharge Time
```

While the lockout feature is on, a padlock icon will appear instead of the usual arrow (>) in front of locked items in the Primary and Advanced / Service menus.

To turn off the lockout feature:

Repeat the procedure just described. Pressing the RECHARGE button while in the warning screen will toggle on/off the lockout feature.

SERVICE / REGENERATION VALVE CYCLE SEQUENCE

UPFLOW SOFTENER

Set to Single, Peak Flow, Parallel Immediate or Parallel Delayed:

Service ➔ Fill ➔ Brine ➔ Backwash ➔ Fast Rinse ➔ Service

Set to Alt. Immediate:

Service ➔ Fill ➔ Brine ➔ Backwash ➔ Fast Rinse ➔ Standby

NOTE: After the first tank has regenerated, it remains in standby and does not return to service until the second tank requires regeneration. The second tank regenerates, then remains in standby and does not return to service until the first tank again requires regeneration.

FILTER

Set to Single, Peak Flow, Parallel Immediate or Parallel Delayed:

Service ➔ Backwash ➔ Fast Rinse ➔ Service

Set to Alt. Immediate:

Service ➔ Backwash ➔ Fast Rinse ➔ Standby

NOTE: After the first tank has backwashed and rinsed, it remains in standby and does not return to service until the second tank requires cleansing. The second tank backwashes and rinses, then remains in standby and does not return to service until the first tank again requires cleansing.

DOWNFLOW SOFTENER

Set to Single, Peak Flow, Parallel Immediate or Parallel Delayed:

Service ➔ Fill ➔ Backwash ➔ Brine ➔ Fast Rinse ➔ Service

Set to Alt. Immediate:

Service ➔ Fill ➔ Backwash ➔ Brine ➔ Fast Rinse ➔ Standby

NOTE: After the first tank has regenerated, it remains in standby and does not return to service until the second tank requires regeneration. The second tank regenerates, then remains in standby and does not return to service until the first tank again requires regeneration.

VALVE POSITION DECAL (located on bottom of controller drive mechanism)

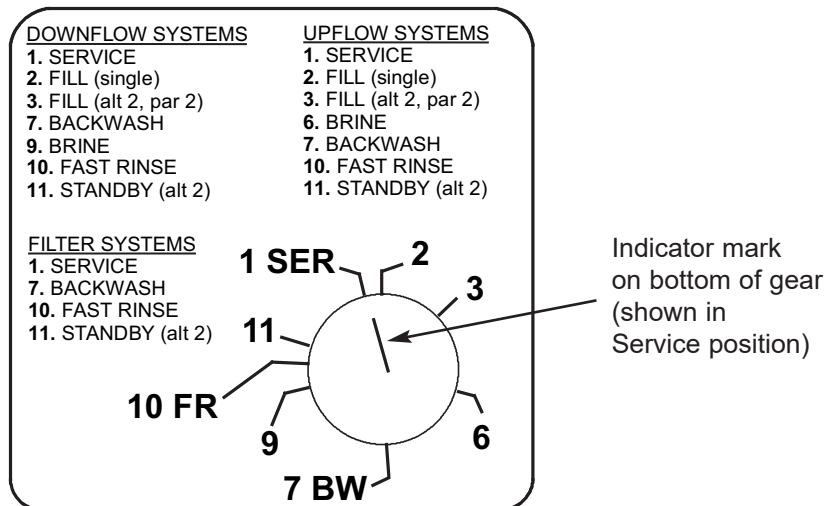

REGENERATION - WATER FLOW THROUGH CONDITIONER

SERVICE

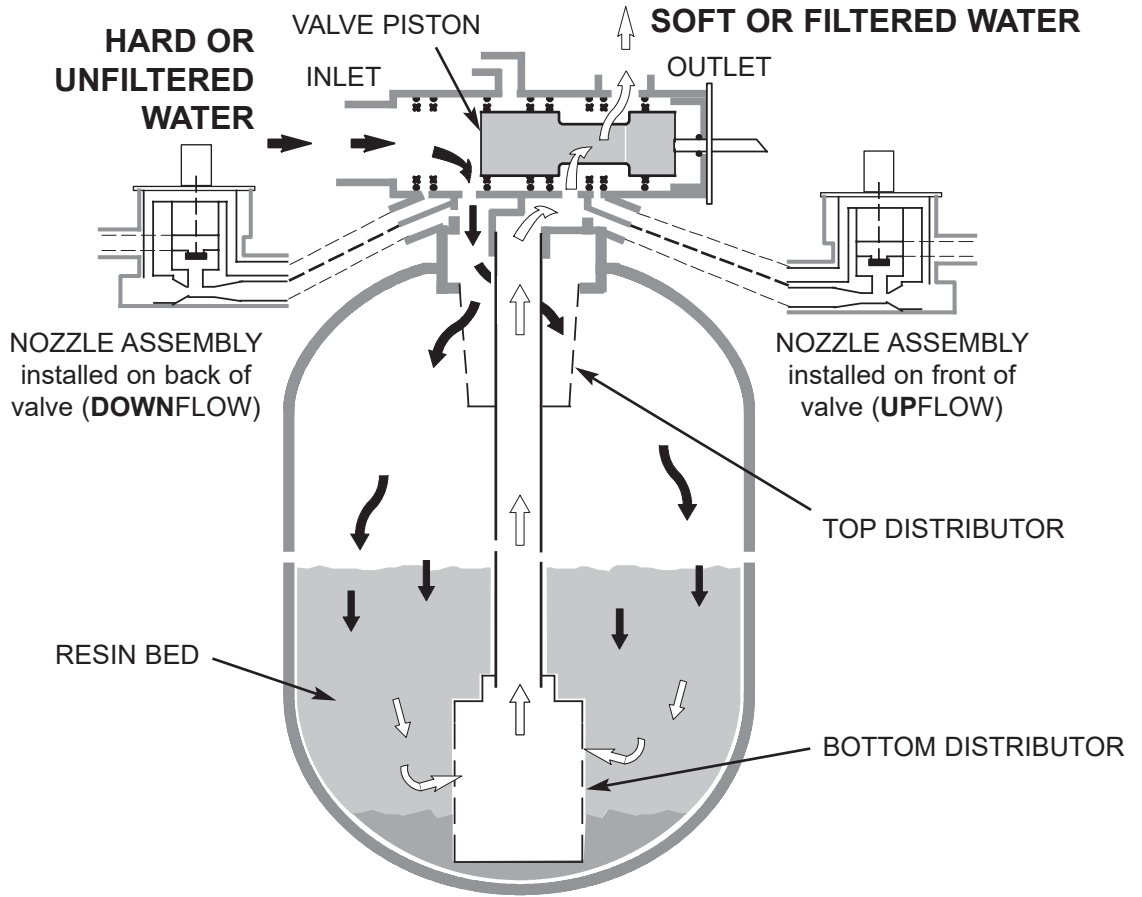

SINGLE TANK FILL (Softener Only)

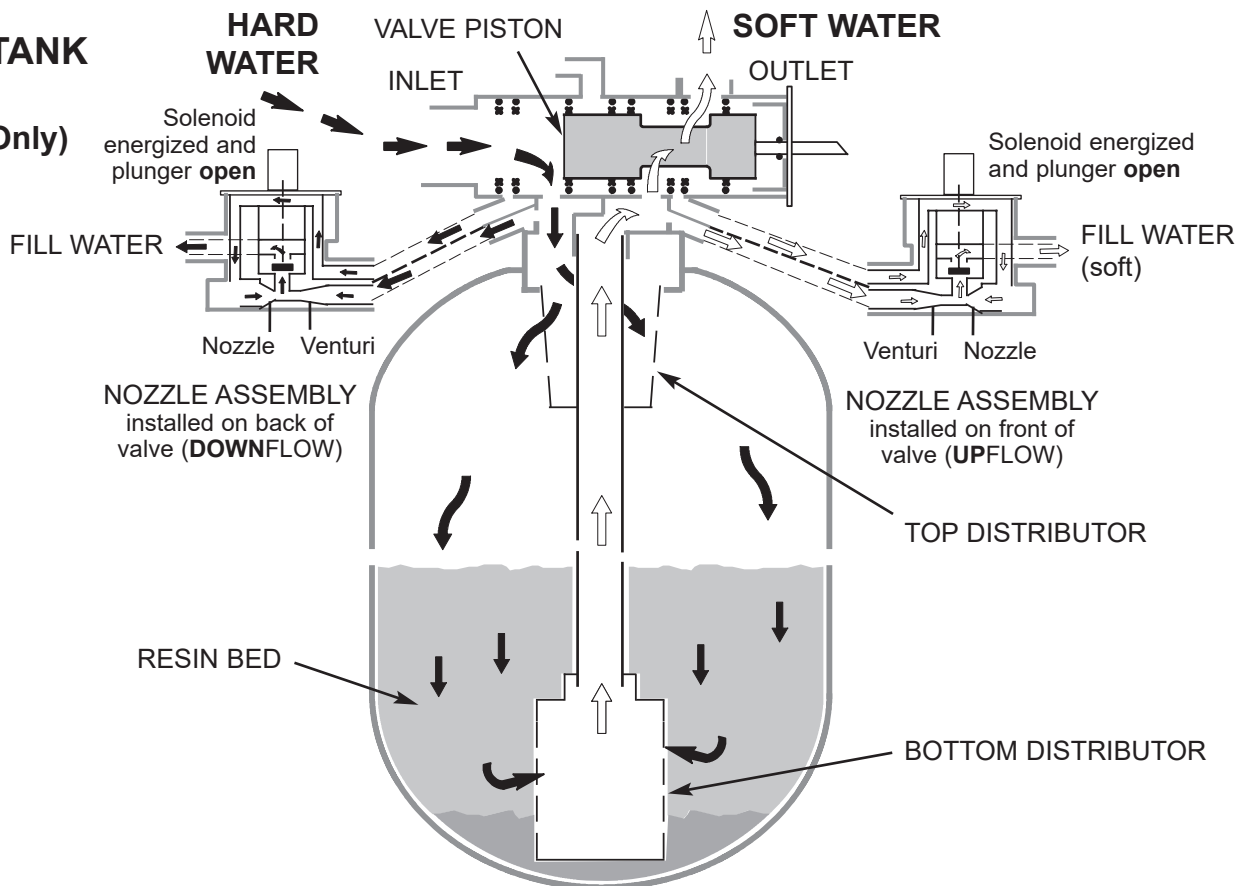

REGENERATION - WATER FLOW THROUGH CONDITIONER

MULTIPLE TANK FILL (Softener Only)

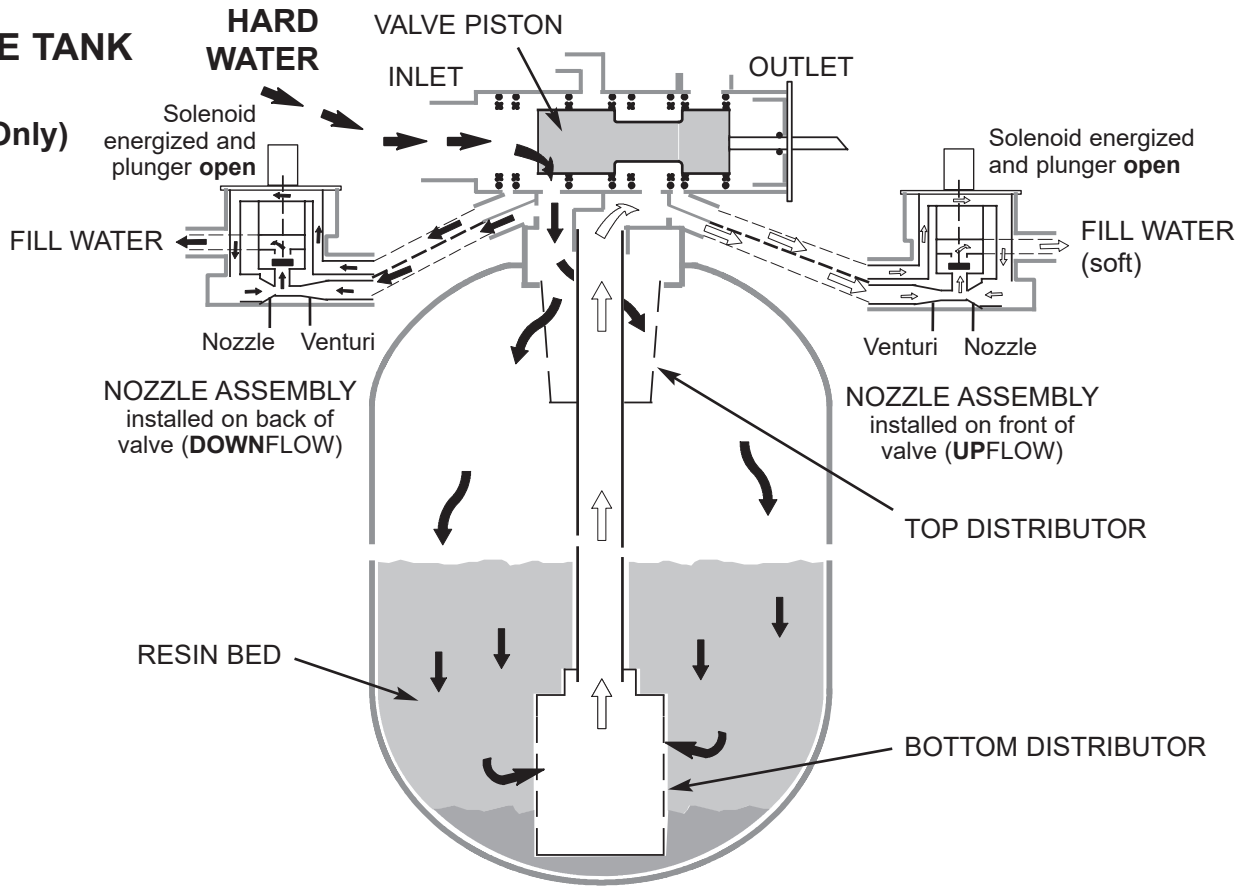

UP-FLOW BRINING & BRINE RINSE (Softener Only)

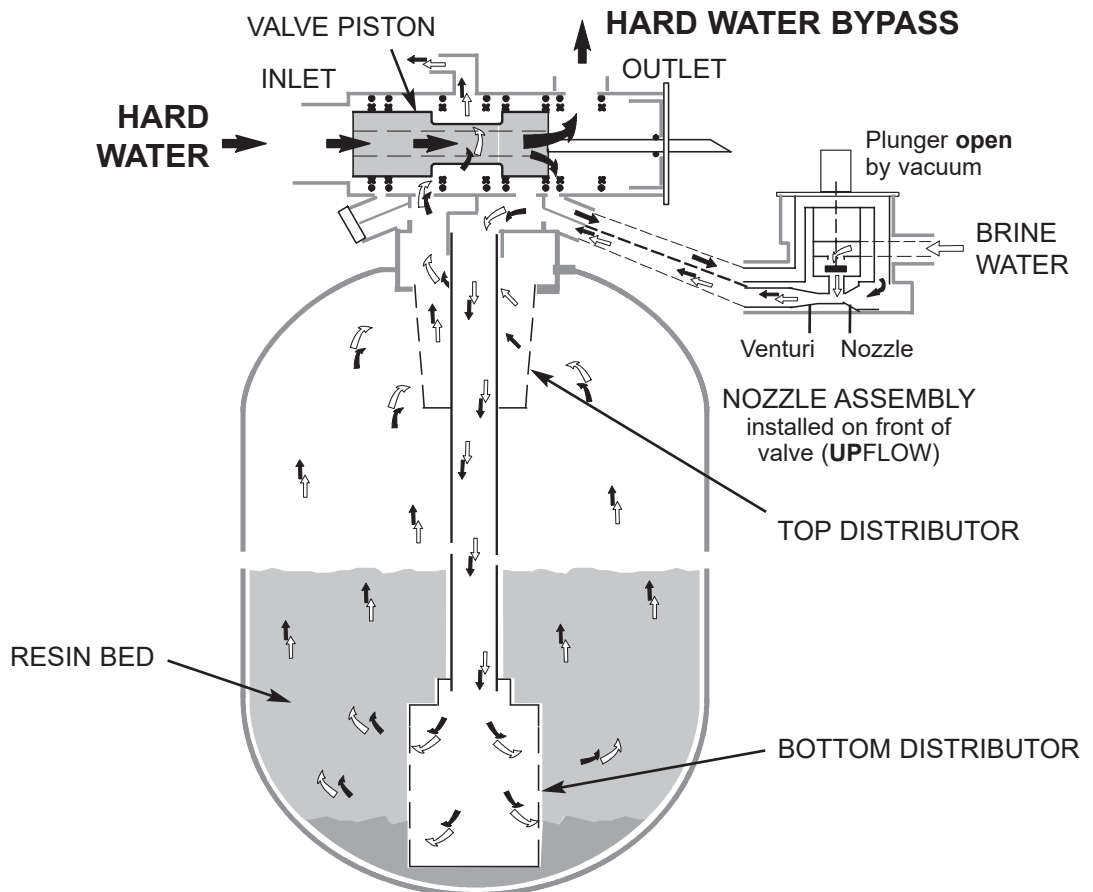

REGENERATION - WATER FLOW THROUGH CONDITIONER

DOWN-FLOW BRINING & BRINE RINSE (Softener Only)

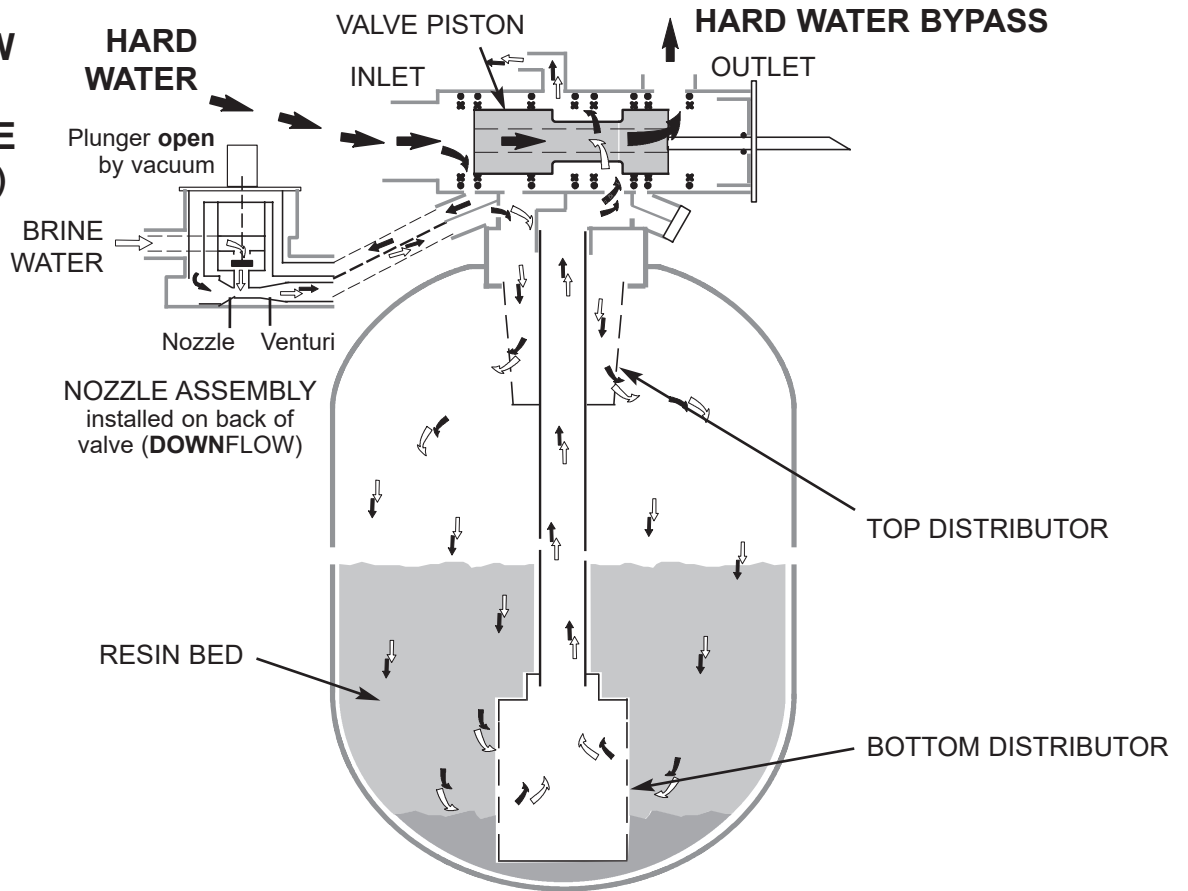

BACKWASH

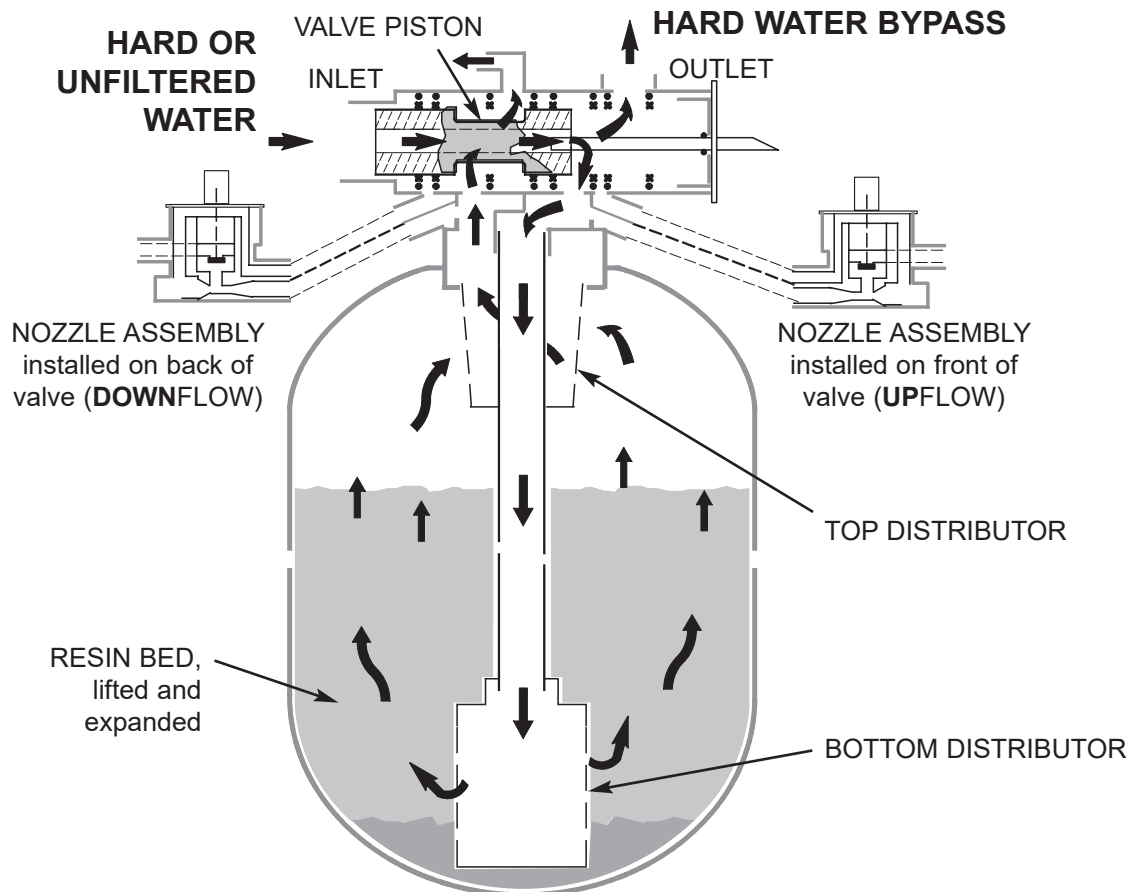

REGENERATION - WATER FLOW THROUGH CONDITIONER

FAST RINSE

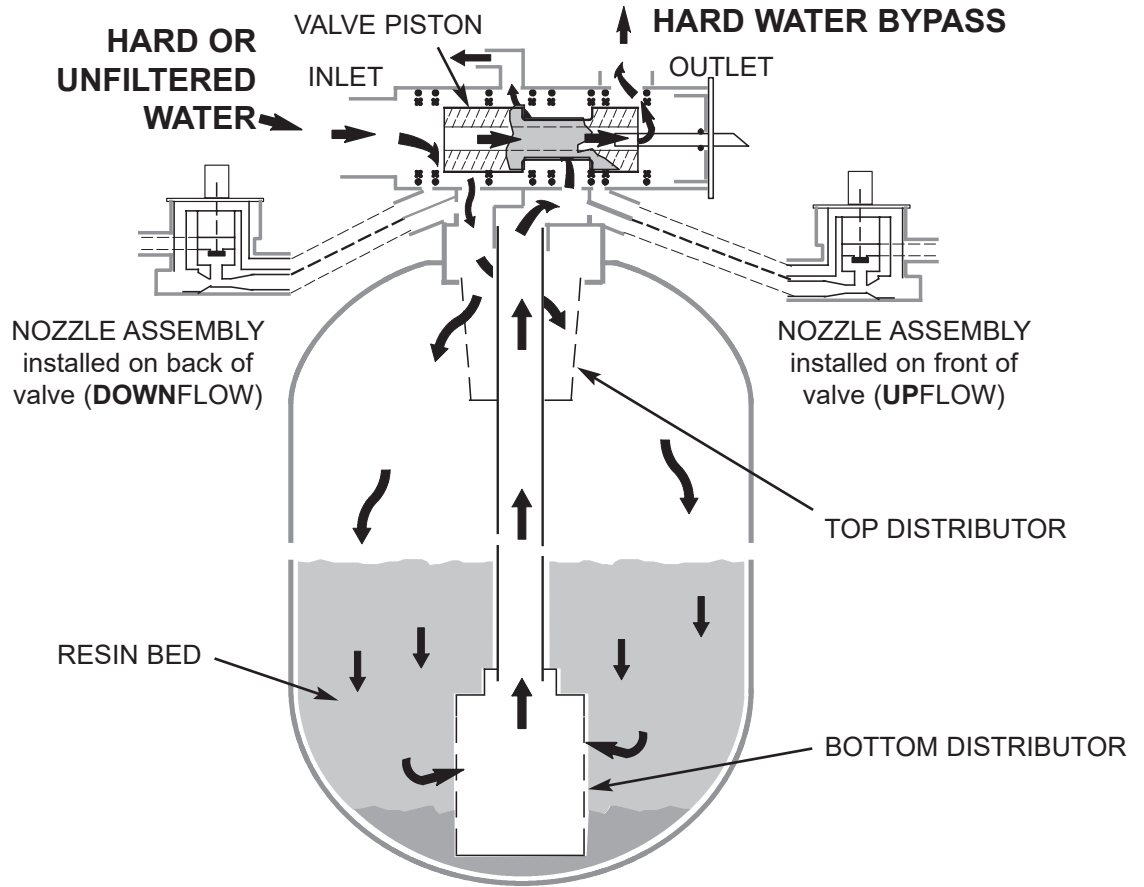

STANDBY - NO WATER FLOW

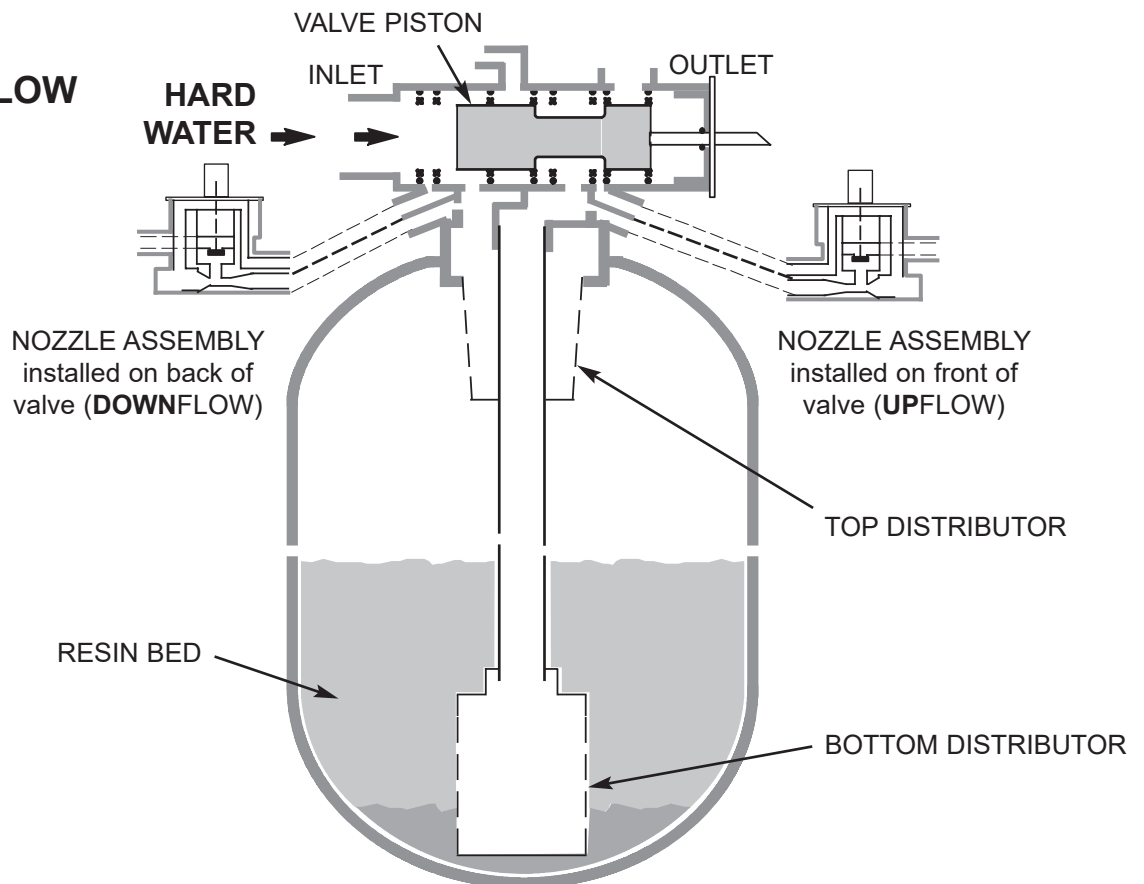

MAINTENANCE

REFILLING WITH SALT

Remove the brine tank cover and check the salt storage level frequently. Refill if less than half full. In humid areas, it is best to keep the salt storage level lower, and to refill more often. Make sure the brinewell cover is on.

RECOMMENDED SALT: Nugget, pellet, button, coarse solar, etc., water conditioner salt is recommended. This type of salt is from high purity evaporated crystals, sometimes formed, or compressed, into briquets. It has less than 1% insoluble (will not dissolve in water) impurities. Clean, high grade rock salts are acceptable, but may require frequent brine tank cleaning to remove the "sludge" residue (insolubles).

SALT NOT RECOMMENDED: Rock salt, high in impurities, block, granulated, table, ice melting, ice cream making salts, etc., are not recommended.

SALT WITH IRON REMOVING ADDITIVES: Some salts have an additive to help a water conditioner handle iron in a water supply. Although this additive may help keep the resin bed clean, it may also release corrosive fumes.

CLEANING NOZZLE/VENTURI & SCREEN

A clean nozzle, venturi, screen and brine line flow control are needed for the softener to work properly. The nozzle and venturi creates the suction to transfer brine solution from the brine tank, into the resin tank. If either should become plugged with iron, sand, silt, dirt, etc., the brine will not get to the resin bed to regenerate it, and you will have hard water.

To clean the nozzle and venturi, refer to the drawing at right. **Be sure to turn off water to the softener and relieve pressure - see next page** (no water pressure at aspirator assembly). Then, to clean parts, including screen, disassemble as shown. Scrub using hot, soapy water and a soft brush. Use care not to scratch or misshape holes in the nozzle and venturi.

Carefully replace all parts in the correct order. If the brine line flow control was disassembled, be sure the flow plug is securely retained by the holder. Lubricate o-ring seals with silicone grease and locate in position. Replace u-pins, retaining clips and the brine elbow clip. Turn on the water and check operation.

BREAKING A SALT BRIDGE

Sometimes, a hard layer or salt bridge forms in the brine tank. This is usually caused by high humidity. If such a layer occurs, salt will not dissolve in the water to make brine. Without brine, the resin bed does not regenerate and you will have hard water.

If the storage tank is full of salt, it is hard to tell if you have a salt bridge. Salt is loose on top, but the bridge is under it. Take a broom handle, or like tool, and push it straight down into the salt. If a hard object is felt, it's most likely a salt bridge. Carefully push into the bridge in several places to break it. Do not pound on the tank walls.

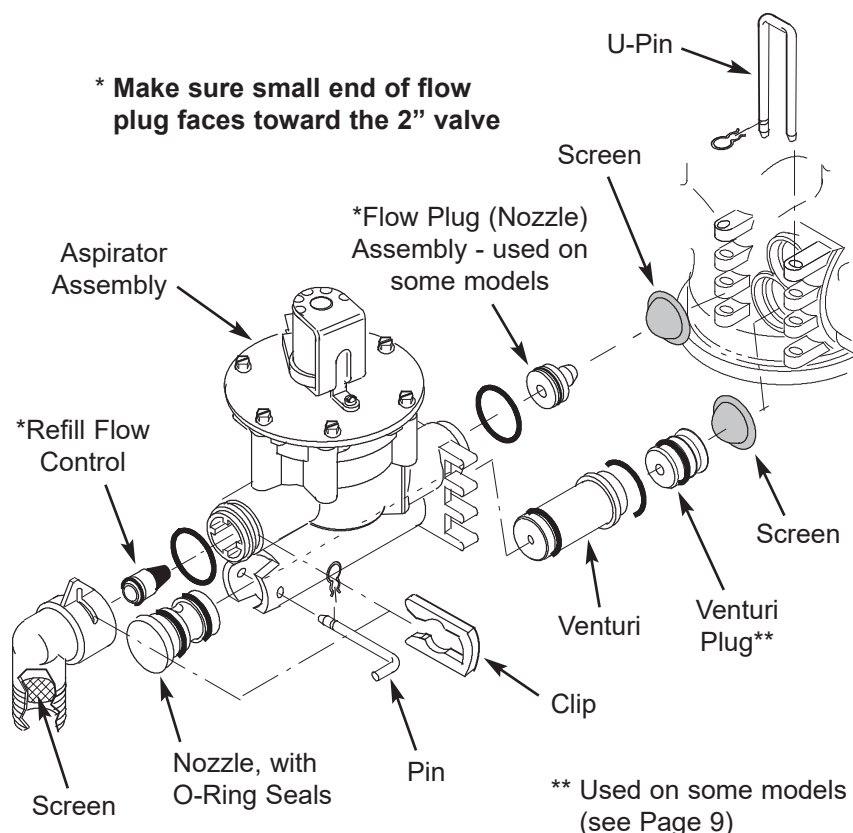

MAINTENANCE

TO RELIEVE WATER PRESSURE

CAUTION: To prevent personal injury, or damage to conditioner parts, do the following steps, in exact order, before working on the valve assembly.

► SINGLE TANK SYSTEM:

1. Check the valve cycle indicator on the bottom of the controller drive mechanism. If not in “service” position, first do step 2. If already in “service”, go to step 3.
2. Press the RECHARGE button and go to the recharge menu. Move the cursor (>) to **Recharge Now** and press the MENU/EXIT (←) button. Move the cursor (>) to **Tank 1** and press the RECHARGE button to start an immediate recharge. Press the RECHARGE button to cycle the valve to “service” position.

```
EXIT
Online / Offline
> Recharge Now
  Recharge Tonight
```

```
EXIT
Recharge All Now
> Tank 1: Fill
```

3. Open the plumbing bypass valve, and close the inlet and outlet plumbing valves.
4. Press the RECHARGE button to advance the valve to “fill” position. Water will bleed out of the resin tank and valve, into the brine tank.
5. Wait until flow to the brine tank stops. Then unplug the power supply. This will prevent accidental advancing of the mechanism and/or piston while working on the controller.

► MULTIPLE TANK SYSTEM OR SINGLE TANK SYSTEM WITH NO ELECTRICAL MEANS TO ADVANCE VALVE:

1. Close the system main water supply valve to turn off water to the softener or filter tank(s).
2. Open plumbing bypass valve(s) and a nearby downstream faucet on soft or filtered water.
3. When flow from faucet stops, close all inlet and outlet plumbing valves.

CAUTION: If multiple tank systems have an optional blocked piston to prevent bypass water during regenerations: Never cycle the valve, when pressurized, with the plumbing bypass valves closed. Damage to the valve, drive mechanism, and motor may occur if water, displaced by the valve piston, cannot enter nearby plumbing. Be sure plumbing valves are open to all tanks before advancing a valve to the next cycle.

CAUTION: To prevent personal injury, or damage to conditioner parts, be sure to turn off the water and relieve pressure before working on the valve assembly or resin tank. The brine valve assembly is pressurized only during the fill cycle of regeneration.

MAINTENANCE

DISASSEMBLY PROCEDURES

► Removing valve assembly from resin tank:

1. Be sure to follow procedures in the previous section to **turn off the water supply and depressurize** the conditioner.
2. Remove clamp retainers and clamp sections from the valve inlet, outlet and drain (be sure all piping is supported).
3. Carefully separate the 2" adaptors, with o-ring seals, from the valve.
4. Remove both retainers and clamps holding the valve to the resin tank adaptor.
5. Lift the valve up and off.

► Removing top distributor from resin tank:

1. Do preceding steps 1-5.

IMPORTANT: When doing the next step, reach through the top distributor support and hold the bottom distributor's riser pipe down while lifting up on the support (refer to fig. 2, page 8). Use a blunt ended tool like a nut driver to hold it down. Do not use a screwdriver or other sharp tool that will damage plastic parts. This will keep the bottom distributor in place and not allow it to lift out of the resin bed. If it lifts, it will be difficult to push it to the bottom of the tank again, because of the gravel base.

2. While holding the riser pipe in place, carefully pry upward on the top distributor support and remove from the tank neck adaptor.
3. Lift the top distributor and screen up and out. Again, be careful not to lift the bottom distributor.

► **Proper Alignment** of Valve Piston with Drive Mechanism and Timer: It is possible for the controller drive mechanism to get "out of alignment" with the valve piston. This can occur:

- If the valve is disassembled for repairs.
- If the bolts (see below) that hold the inner bracket assembly in place, loosen.

When out of alignment, you may notice poor brine draw characteristics, and/or hard water "bleed" from a conditioner in standby.

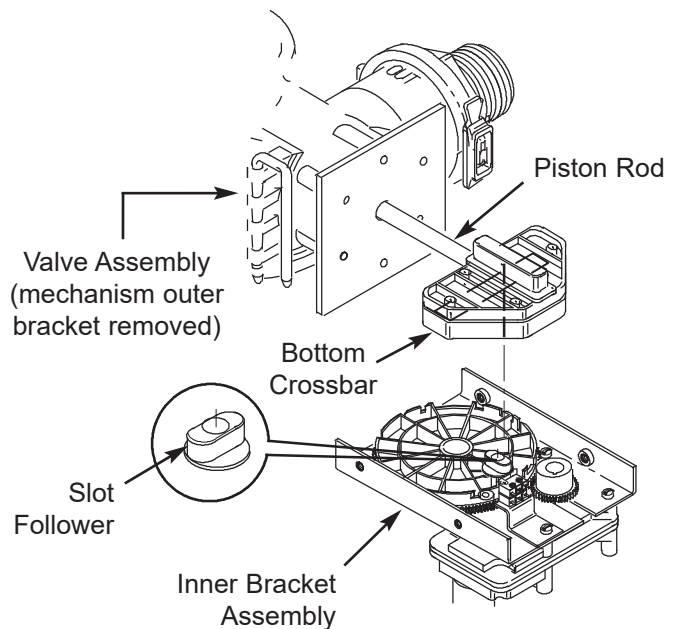
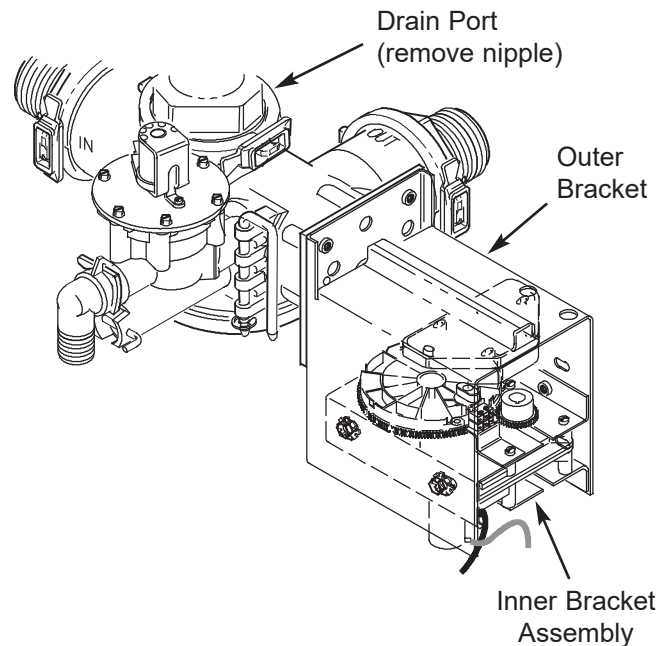

MAINTENANCE

TO ALIGN

1. Use the manual advance procedures (page 38) to cycle the valve into backwash. Verify by observing the decal on the bottom of the drive mechanism, and a fast flow to the drain.
2. Place plumbing bypass valves in bypass position (see page 12). Pressure will vent to the drain.
3. Unplug the power supply. This will prevent accidental cycling to the next position.
4. Loosen the 4 hex-head screws holding the inner bracket assembly in place (see drawing on previous page).
5. Remove retainers and pull the u-pins holding the aspirator assembly in place. Remove the aspirator assembly and screens from the valve.

NOTE: You can also check for piston alignment, with alignment marks, at the alternate aspirator assembly mounting location (remove plug), or at the drain port (remove drain nipple).

6. Look into the bottom aspirator port. The back edge of the piston must align with one of the marks on the exposed ribs of a lantern ring. If it does not, push or pull on the inner bracket assembly (slides in elongated holes in outer bracket) until aligned.

NOTE: If properly aligned, elongated holes in the outer bracket will center over threaded holes in the inner bracket.

7. Tighten all hex-head screws and lock washers to fasten the inner bracket in place.

8. Plug the power supply back in, pressurize and verify correct operation using the manual advance procedures.

► **Valve seal and ring locations:** Locate lantern rings, quad ring seals and o-ring seals exactly as shown below.

NOTE: Be sure to install the far, righthand-most o-ring seal onto the end plug. Do not install on the lantern ring.

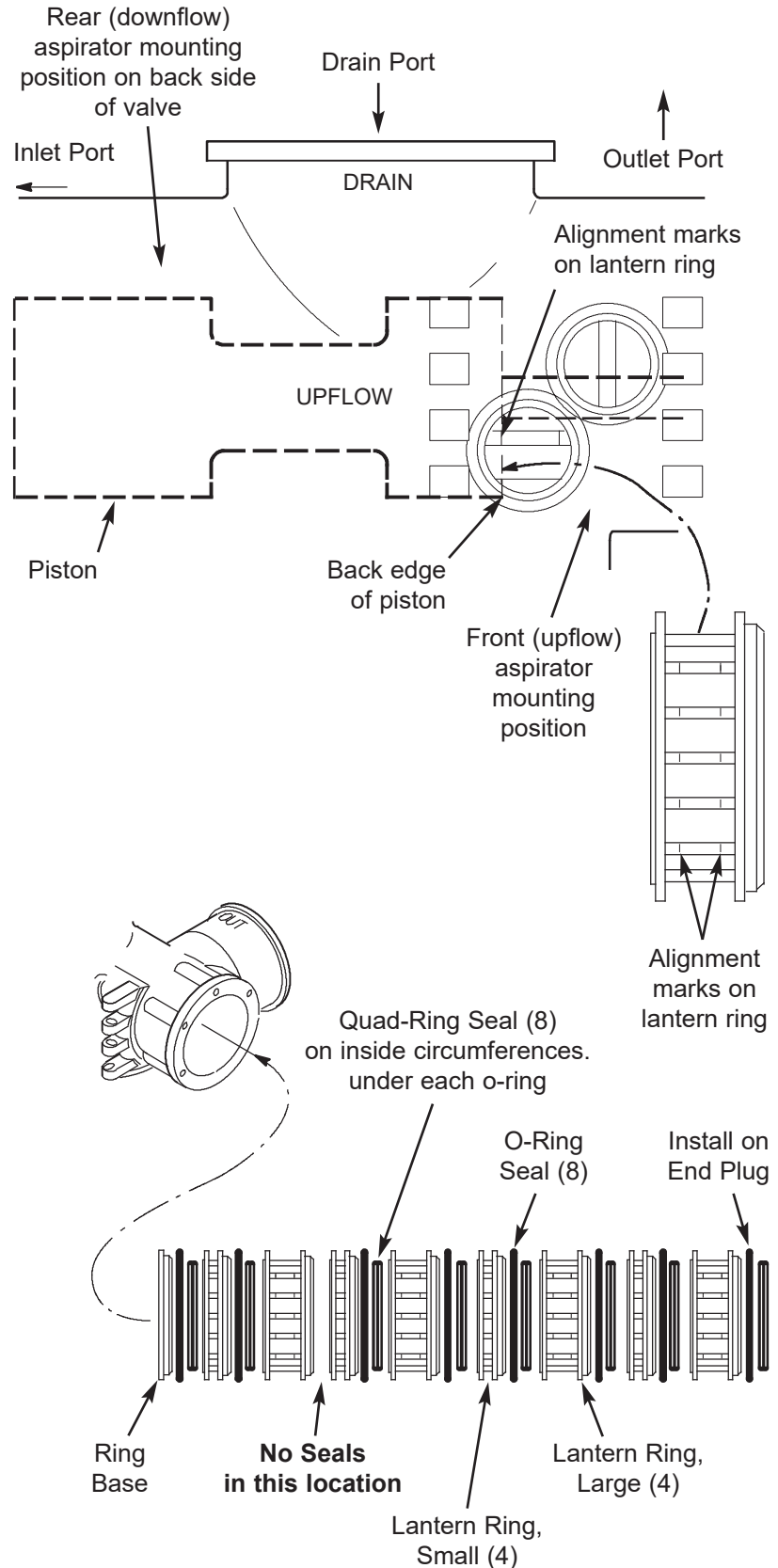

TROUBLESHOOTING

ALWAYS MAKE THESE INITIAL CHECKS FIRST:

1. Does the time display show the correct time of day?
 - If display is blank, check power source to the conditioner.
 - If display is blank, check the fuse on the power cable.
 - If time is flashing, power was off for longer than the built-in program memory. The conditioner will resume normal operation when power returns, but regenerations may occur at the wrong time.
 - If an error code shows in the display (example: Error3), go to “Automatic Electronic Diagnostics”, below.
2. Plumbing bypass valve(s) must be in “service” position (all the way open or closed, as applies - see page 12).
3. Inlet, outlet and drain pipes must connect to the conditioner, as typically shown on page 12.
4. Is the power supply plugged into a “live”, grounded wall outlet, and the power cable fastened securely?
5. Is there salt in the brine tank? Check to be sure it is not bridged or caked (see page 32).
6. Is the brine tubing connected? See step 5, page 14.
7. Double check the “Hardness” setting. Press the MENU/EXIT (←) button, move the cursor (>) to **Set Hardness** and press the MENU/EXIT (←) button. Make sure it is the correct setting for the water supply. Perform a hardness test of the raw water and compare with the hardness setting. If the water contains iron, be sure to add 5 to the hardness number for each 1 ppm or iron. Also test a conditioned water sample to verify if a problem exists. Press the MENU/EXIT (←) button to return to the primary menu, move cursor to **EXIT** and return to the normal operating screen.

If you do not find a problem after making the initial checks, do “Manual Electronic Diagnostics”, and the “Manual Advance Regeneration Check”, following.

AUTOMATIC ELECTRICAL DIAGNOSTICS

The electronic controller has a self-diagnostic function for the electrical system (except input power and water meter). The controller monitors electronic components and circuits for correct operation. If a malfunction occurs, an error code appears in the display on the electronic box.



```
Error # 3      3:45 PM
Tank # 1
Recharge to Retry
← Menu
```

The chart on the next page shows the error codes that could appear, and the possible defects for each code. While an error code appears in the display, the tank is taken offline and either the RECHARGE button or MENU/EXIT (←) button can be used. MENU/EXIT (←) remains operational so the service person can perform the “Manual Electronic Diagnostics” to further isolate the defect, and check the water meter.

If RECHARGE is pressed, the display will show the “Diagnostics” screen and cycle the valve through all positions to try to correct the error itself. After it is done retrying, the display reverts back to the run screen (either showing error code again or normal run screens).

If the controller successfully fixes the problem in the diagnostics display, the unit automatically is placed back online by the software. There would be no need to go into the online/offline screen to put the unit back online.

TROUBLESHOOTING

PROBLEM	POSSIBLE CAUSE	POSSIBLE CORRECTION
No display.	No power to outlet.	Check the outlet by plugging in another appliance.
	Fuse blown.	Check fuse in power cable. REPLACE WITH SAME TYPE AND VALUE: AGC 3A 250V.
	Internal power supply fuse blown.	Plug the power supply into an outlet and measure output voltage with a multi-meter. Should be between 24 and 30 volts DC.
Fuse keeps blowing.	Wiring harness shorted or not connected properly.	Check connections at controller box and valve. Connect all other wires before plugging power supply into outlet.
Cannot set some control parameters and display shows a padlock icon: 	Lockout feature is on.	Turn off lockout feature (see page 26).
Error code 1, 3 or 4 displayed.	Wiring harness not connected or not connected properly.	Check connections at controller box and valve. Check for corrosion at connection points.
	Incorrect position switch connections.	Check valve switch connections.
	Incorrect valve type selected on new install or upgrade to system.	Check that proper valve configuration is selected on controller box.
	Valve motor running slow, or not at all.	Initiate a recharge and step valve through all positions. Check motor for consistent movement. If slow, check motor and valve seals; lubricate piston.
Error code 6 displayed.	Optional immediate regeneration switch is stuck in the on position.	Check red wires from power cable for possible shorts. Check immediate regeneration switch, if installed.

Procedure for removing error code from faceplate:

Press the RECHARGE button, or: **1.** Unplug power supply. **2.** Correct problem. **3.** Plug in power supply. **4.** Wait for 6 minutes. The error code will return if the problem was not corrected.

MANUAL ELECTRONIC DIAGNOSTICS

1. Do the preceding (page 36) "Initial Checks" first.
2. Enter the diagnostics screen on the controller (page 36) and using the DOWN (▼) button, view the turbine information.

```

Pos: Service 0:00 ↑
Req Pos: Service
Motor:Off Sw:Open
Trbn:000 Gals:0 ↓
    
```

The 3 digits after "Trbn:" indicate water meter operation as follows:

- 000 (steady)** = conditioned water not in use - no flow through the meter.
- open a nearby conditioned water faucet -**
- 000 to 045 (continual)** = repeats display for each gallon of water passing through the meter.

If you don't get a reading in the display, check the turbine connection to the electronic box. If the connection is okay and good contact is made, turn off the water supply and remove the turbine / sensor assembly (4 screws) from the water meter body. Check the turbine for obstruction or binding. If okay and you still do not get a reading, the sensor is probably defective.

NOTE: When the position or regeneration switch lever and plunger are depressed, the switch is closed

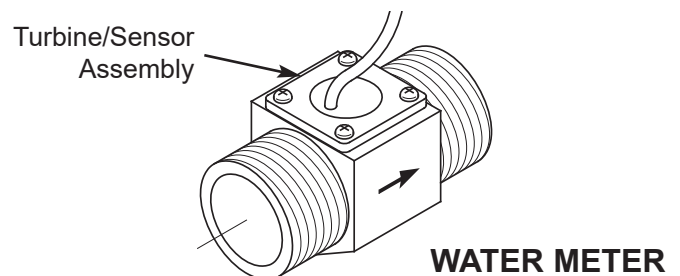

TROUBLESHOOTING

MANUAL ADVANCE REGENERATION CHECK

This check verifies proper operation of the gear-motor, brine tank fill, brine draw, regeneration flow rates, and other controller functions. Always make the initial checks, and the manual initiated diagnostics first.

NOTES: 1) A steady time, not flashing, must show in the display. 2) Refer to the valve cycle chart on page 27 for cycle sequences. 3) To verify the valve position, look at the decal on the bottom of the controller.

CAUTION: Multiple tank systems with blocked pistons to prevent bypass water during regenerations: Never cycle a valve, when pressurized, with the plumbing bypass valves closed. Damage to the valve, drive mechanism, and motor may occur if water, displaced by the valve piston, cannot enter nearby plumbing. Be sure plumbing valves are open to all tanks before advancing a valve to the next cycle.

In this procedure you will use the RECHARGE button to manually advance the valve into each position and check the various valve cycles.

```
EXIT
Online / Offline
> Recharge Now
  Recharge Tonight
```

```
EXIT
Recharge All Now
> Tank 1: Fill
  Tank 2: Service
```

1. Press the RECHARGE button to enter the recharge menu. Move the cursor (>) to **Recharge Now** and press the MENU/EXIT (←) button.

2. Move the cursor (>) to the tank you wish to check.

3. Press the RECHARGE button to advance the valve through each position in the recharge sequence.

FILL: Remove the brinewell cover and, using a flashlight, observe fill water entering the tank.

NOTE: The aspirator solenoid is energized and open during the fill cycle. You can usually hear the solenoid “click” and “buzz”.

a. If water does not enter the tank, look for an obstructed nozzle and venturi, fill flow control, screen(s), brine tubing or defective solenoid.

CAUTION: Softener must be depressurized before removing aspirator assembly.

BRINING: A slow flow of water to the drain will begin. Verify brine draw from the brine tank by shining the flashlight into the brinewell and observing a noticeable drop in the liquid level.

NOTE: Be sure water is in contact with the salt, and not separated by a salt bridge (see page 32).

a. If the unit does not draw brine, check for:

- Dirty or defective nozzle and venturi (see page 32).
- Restriction in valve drain, causing a back-pressure (bends, kinks, elevated too high, etc.).
- Obstruction in brine valve or brine tubing.
- Inner valve failure (obstructed or defective o-ring / quad-ring seals, piston).

BACKWASH: Look for a fast flow of water from the drain.

a. If flow is slow, check for a plugged top distributor screen, internal riser pipe, backwash flow controls, drain piping, fouled resin bed, etc.

FAST RINSE: Again look for a fast drain flow. Allow the unit to rinse for several minutes to flush out any brine that may remain from the brining cycle test.

1. To return the valve to service position, press the RECHARGE button once again.

NOTE: On multiple tank systems, if you use the “Recharge All Now” option, the first tank advances to the service position before the second tank begins the regeneration cycle.

NOZZLE / FLOW PLUG USAGE & IDENTIFICATION CHART

SOFTENER MODEL	Fill Control & Nozzle/Venturi Requirements					Drain Flow Control Requirements			
	Regen. Water Flow	① Water Pressure	Nozzle/Venturi Color	Flow Plug gpm / color	Sleeve Req. (small)	Fill Flow Plug gpm / color②	Backwash/Rinse Flow Plug gpm / color②	Sleeve Req'd (large)	Solid Plugs Req'd
102, 102-1, 132, 132-1, 162, 162-1	UP flow	Low	Purple	–	–	1.0 / Green	7 / Brown	Yes	3
		Med.	Purple	0.6 / Blue	Yes				
		High	Green	0.4 / Lt. Blue	Yes				
	DOWN flow	Low	Black	–	–	1.0 / Green	7 / Brown	Yes	3
		Med.	Red						
		High	Gray						
192, 192-1, 252, 252-1, 322, 322-1	UP flow	Low	Red	1.0 / Green	Yes	2.0 / Brown	12 / Red	No	3
		Med.	Gray	–	–				
		High	Red	0.8 / Orange	Yes				
	DOWN flow	Low	Yellow	–	–	2.0 / Brown	12 / Red	No	3
		Med.	Black						
		High	Red						
362, 452	UP flow	Low	Black	–	–	3.0 / Tan	12 / Red (2)	No	2
		Med.	Red	1.2 / Yellow	Yes				
		High	Gray	–	–				
	DOWN flow	Low	Orange	–	–	3.0 / Tan	12 / Red (2)	No	2
		Med.	Blue						
		High	Yellow						
602	UP flow	Low	Yellow	–	–	3.5/Purple	12 / Red, 20 / White (1 of each)	No	2
		Med.	Black						
		High	Red						
	DOWN flow	Low	White	–	–	3.5/Purple	12 / Red, 20 / White (1 of each)	No	2
		Med.	Orange						
		High	Blue						

① See pressure ranges on page 10

② On most flow plugs, identification is by colored dot on black rubber

	MODEL									
	102, 102-1	132, 132-1	162, 162-1	192, 192-1	252, 252-1	322, 322-1	362	452	602	
Fill Cycle Flow Rate (gpm)	1.0/Green	1.0/Green	1.0/Green	2.0/Brown	2.0/Brown	2.0/Brown	3.0 / Tan	3.0 / Tan	3.5/Purple	
Fill Flow Plug Location	See illustration on page 32									
Brine Cycle Flow Rate (gpm)	0.58	0.57	1.1	1.1	1.1	1.1	1.76	1.76	2.59	
Br. Rinse Cycle Flow Rate (gpm)	0.48	0.47	0.89	0.89	0.89	0.89	1.29	1.29	2.02	
Backwash Cycle & Fast Rinse Cycle Flow Rate (gpm)	7	7	7	12	12	12	24	24	32	
Backwash & Fast Rinse Flow Plug Identification & Location	7 / Brown			12 / Red			12 / Red (2)		12 / Red, 20 / White	
	See drain adaptor									
Gravel Amount (lbs)	Fine	50	50	50	100	100	100	150	150	250
	Med.	50	50	50	100	100	100	150	150	150
Freeboard (inches)③	25	18	24	37	29	21	32	25	28	
Brining/Br. Rinse Cycle Time (min.)④	Low Salt	115	150	180	110	145	180	140	175	160
	High Salt	95	125	154	80	120	150	115	140	130
Backwash Cycle Time (min.)⑤	12	12	12	14	14	14	15	15	15	
Fast Rinse Cycle Time (min.)⑤	5	5	5	10	10	10	12	12	12	

③ Nominal distance from top of resin bed to top of tank. This dimension can vary several inches, depending on resin moisture content, degree of bed expansion or packing, resin tank tolerances, etc.

④ Cycle times for upflow brining (for downflow brining, see page 21)

⑤ Factory default setting (see page 21)

NOZZLE / FLOW PLUG USAGE & IDENTIFICATION CHART

FILTER MODEL	Drain Flow Control Requirements			
	Filter Type	Flow Rate (gpm)	Flow Plug gpm / color*	Solid Plugs Req'd
172, 172-1	Carbon	15	15 / Black	3
	Greensand / Multimedia	24	12 / Red (2)	2
242, 242-1	Carbon	30	15 / Black (2)	2
	Greensand / Multimedia	50	15 / Black (2), 20 / Black - White Dot	1
302	Carbon	50		
	Greensand / Multimedia	70	15 / Black (2), 20 / Black - White Dot (2)	-
362	Carbon	70		

* On most flow plugs, identification is by colored dot on black rubber

NOTE: Multiple units require only one power supply

WIRING CONNECTION DIAGRAM

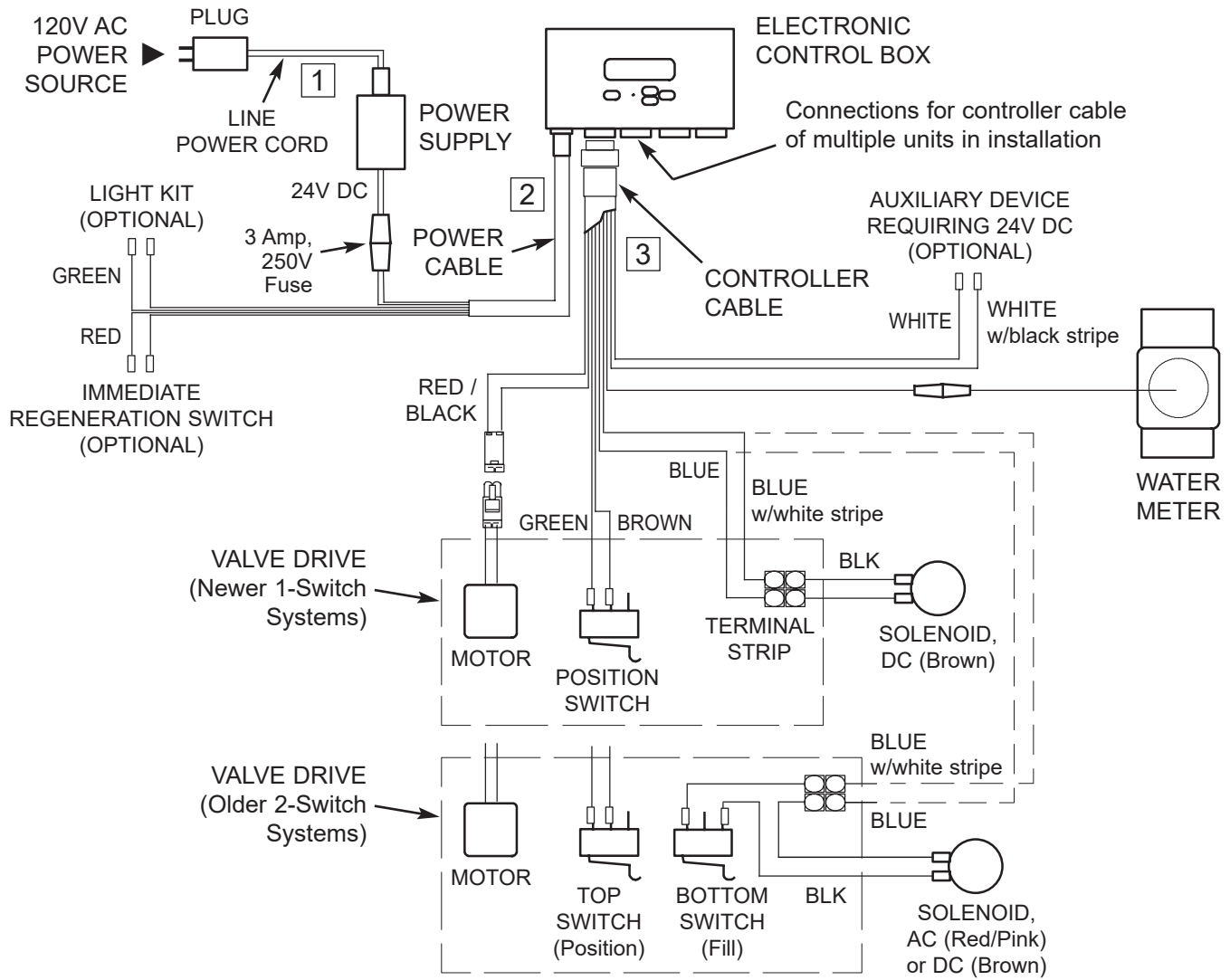

Newer 1-Switch Systems

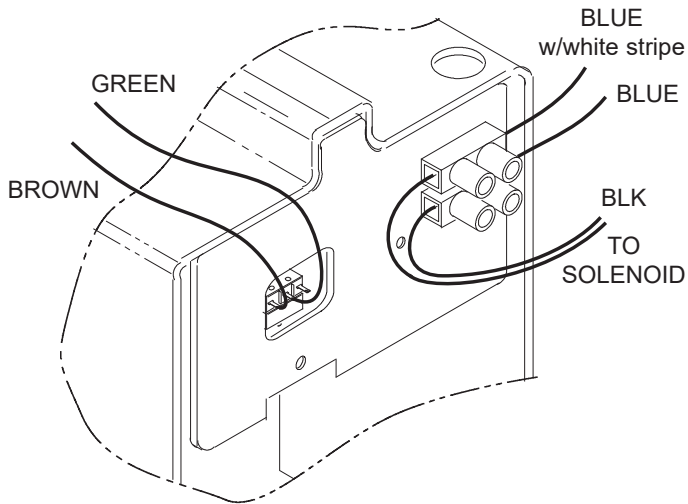

Older 2-Switch Systems

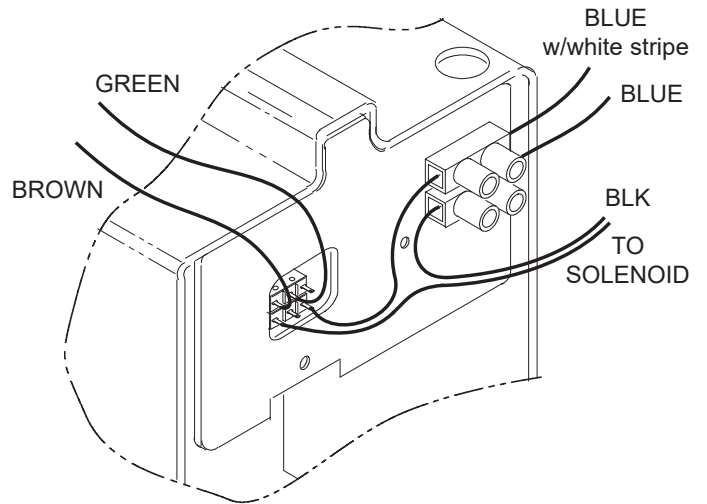

REPAIR PARTS - RESIN & BRINE TANK ASSEMBLIES

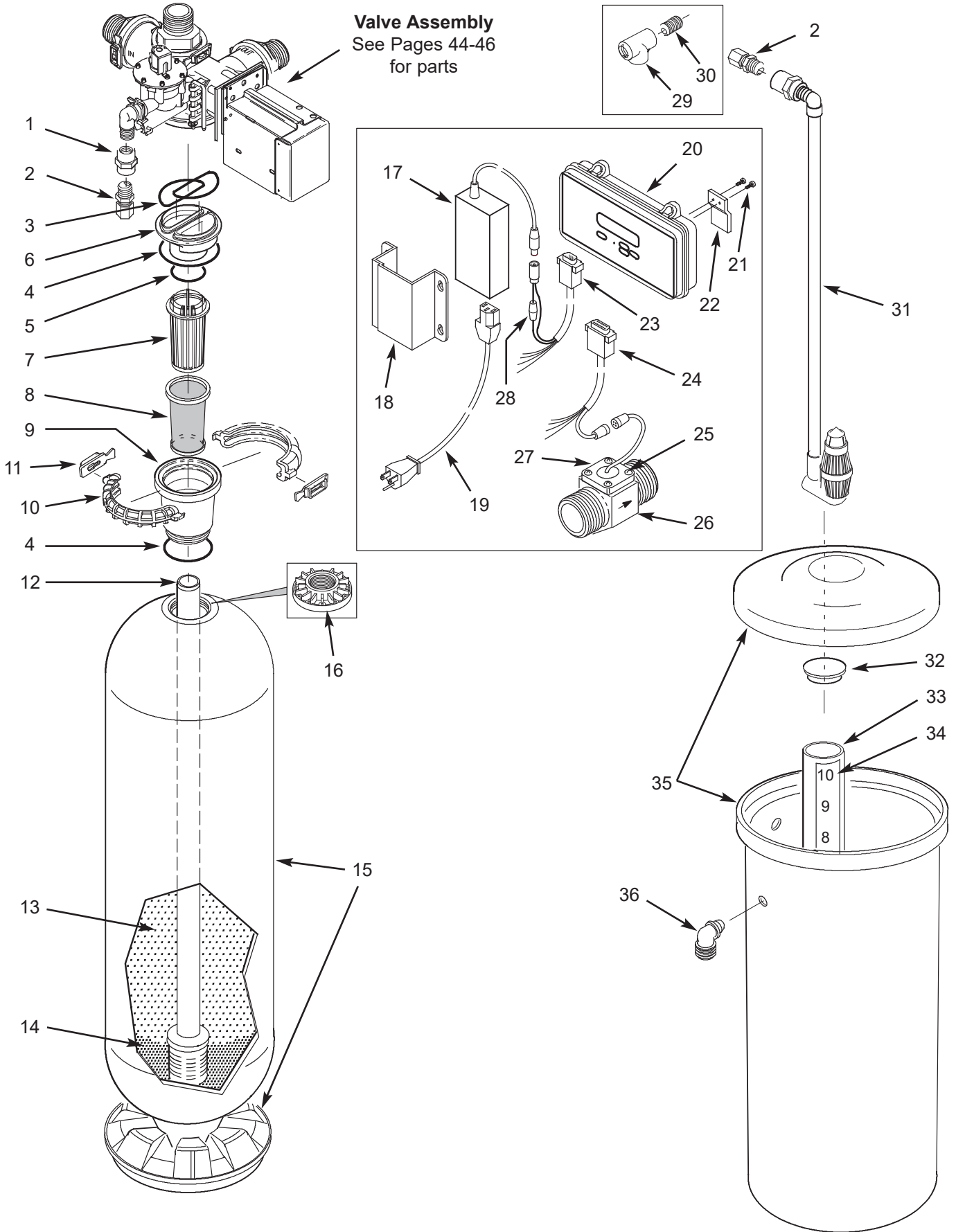

REPAIR PARTS - RESIN & BRINE TANK ASSEMBLIES

Key No.	Part No.	Description
1	7175678	Reducer, 3/4" x 1/2"
2	7138210	Connector, 1/2" NPT x 1/2" Tube (2 req.)
■	7190377	Tubing, 1/2" x 8 ft.
-	7345833	2" Valve O-Ring Kit (includes 5 ea. of Key No. 3, 2 ea. of Key No.4 & 1 ea. of Key No. 5)
3	7170296	O-Ring, 2-7/8" x 3-1/4", single (2 req.)
4	9001100	O-Ring, 4-1/8" x 4-1/2" (2 req.)
5	9001102	O-Ring, 2-3/8" x 2-3/4"
6	7165291	Support, Top Distributor
7	7165283	Top Distributor
8	7169813	Screen
9	7169902	Tank Adaptor
10	7145217	Clamp (2 req.)
11	7088033	Clamp Retainer (2 req.)
12	7243625	Distributor (bottom) Assembly
13	0502272	Resin, 1 cu. ft. ①
	7336834	Activated Carbon, 1 cu. ft. ①
	7331101	Greensand Plus, 1/2 cu. ft. ①
	0993070	Anthracite (lb.) ①
	0993090	Garnet (lb.) ①
14	0993080	Filter Sand (lb.) ①
	7124415	Gravel - Fine, 17 lbs ①
	7124423	Gravel - Fine, 50 lbs. ①
	7127073	Gravel - Medium, 50 lbs. ①
15	4104600	Gravel - Coarse, 17 lbs. ①
	×	Resin Tank w/base, 17" dia. x 58"
	7391787	Resin Tank w/base, 16" dia. x 65" ▲
	7153561	Resin Tank w/base, 17" dia. x 72"
	7391795	Resin Tank w/base, 18" dia. x 65" ▲
	×	Resin Tank w/base, 24" dia. x 72"
	7391800	Resin Tank w/base, 24" dia. x 72" ▲
	0403007	Resin Tank w/base, 30" dia. x 72"
0403006	Resin Tank w/base, 36" dia. x 72"	

Key No.	Part No.	Description
16	7345516	Adaptor, for 30" & 36" dia. tanks (incl. o-ring & installation hardware)
17	7362673	Power Supply, 24V DC, 65W
18	7377987	Bracket, Power Supply
19	7362720	Line Power Cord
20	7362453	Control Box, CUC2, EcoWater
21	9006029	Screw, #6-20 x 5/16" (2 req.)
22	0502080	Hanger, Control Box
23	7362607	Power Cable, CUC2
24	7285481	Repl. Control Cable
25	0900386	Screw, #8-32 x 1/2" (4 req.)
	0810037	Washer (4 req.)
26	7251377	Water Meter Housing
27	7345930	Repl. Turbine Assembly, Gray
28		Fuse, AGC 3A 250V - purchase locally - replace with same type and value only
29	7194622	Tee, 1/2" NPT - multiple tank systems
30	7194630	Nipple, 1/2" NPT - multiple tank systems
31	7222085	Air Check, 50" & 51" high tanks (includes Key Nos. 33-35)
32	0500283	Cover, Brinewell
	7222051	Cover, Brinewell, 51" high tank
33	0980067	Brinewell, 50" & 51" high tanks
34	7243853	Decal, Brinewell
35	7227027	Brine Tank w/cover, 24" x 50" (includes Key Nos. 31 & 36)
	7227035	Brine Tank w/cover, 31" x 51" (includes Key Nos. 31 & 36)
	940027	Brine Tank w/cover) 41" x 51" (includes Key Nos. 31 & 36)
36	0523819	Drain Elbow

ACCESSORIES

■	7286005	Controller Extension Cable, 20 ft.
---	---------	------------------------------------

■ Not illustrated.

① See page 3 for amounts required.

▲ For models ending with "-1" (example: 102S-1).

× No longer available.

REPAIR PARTS - 2" VALVE

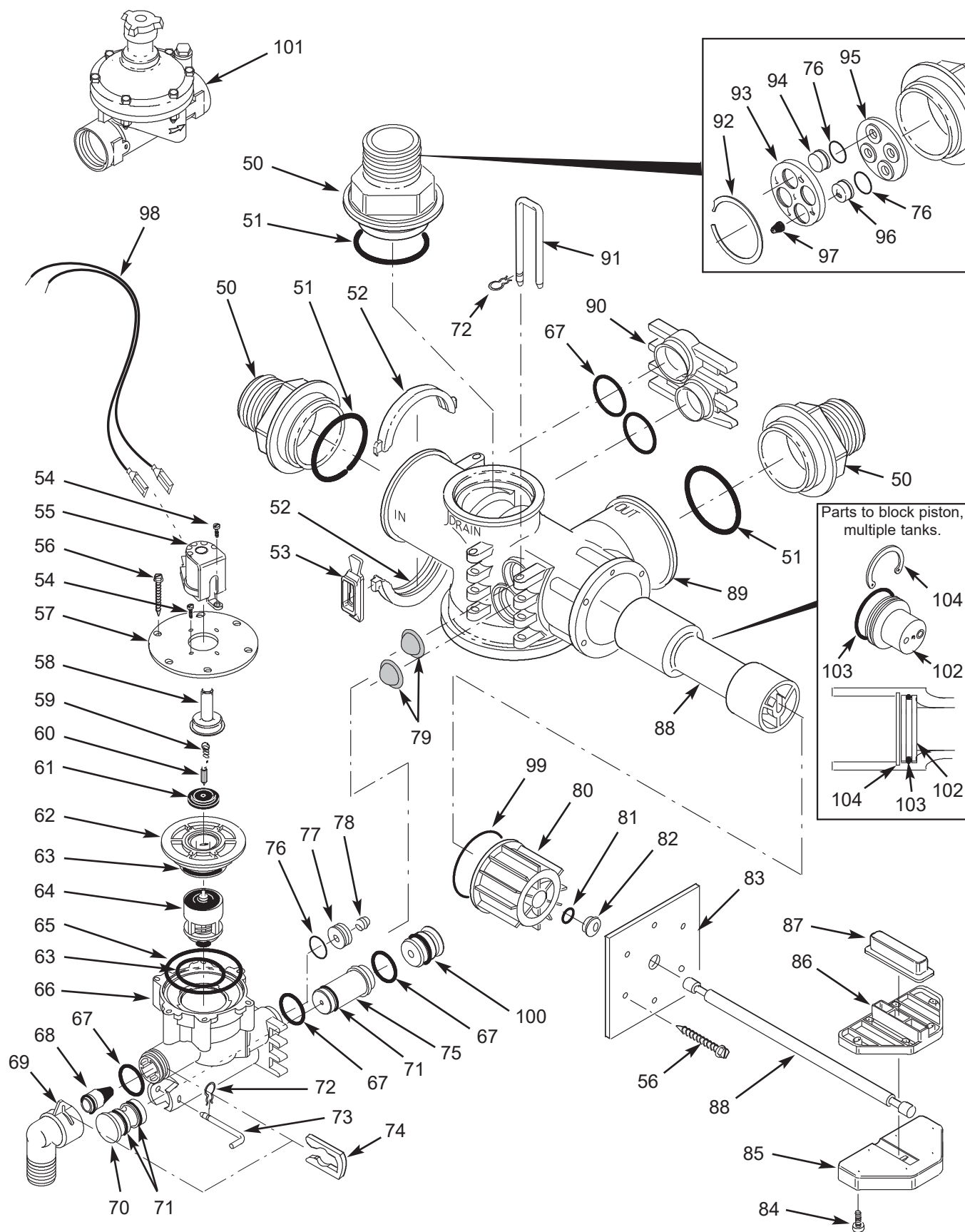

REPAIR PARTS - 2" VALVE

Key No.	Part No.	Description
50	7174460	Nipple, 2", Inlet/Outlet (3 req.)
51	7170296	O-Ring, 2-7/8" x 3-1/4", single (3 req.), included in 2" Valve O-Ring Kit #7345833 shown on Page 43.
	7336452	O-Ring, 2-7/8" x 3-1/4", pack of 20
-	7331177	Tank Neck Clamp Kit (includes 2 ea. of Key Nos. 52 & 53)
52	↑	Clamp Section (6 req., 4 not shown)
53	↑	Retainer Clip (6 req., 5 not shown)
54	9006029	Screw, #6-20 x 5-1/16" (4 req.)
-	7368069	Solenoid Assembly, DC (includes Key Nos. 55, 58, 59, 60 & 61)
55	7362398	Solenoid Coil, 24V DC, Brown
56	9006042	Screw, #10-14 x 1-1/14" (12 req.)
57	7288146	Mounting Plate
58	7003334	Solenoid Guide
59	7003342	Solenoid Spring
60	7003350	Armature
-	7195212	Aspirator Seal Kit (includes Key Nos. 61, 63, 64, 65, 67 & 71)
61	7003368	Diaphragm
62	7168087	Aspirator Cap
63	7169886	O-Ring, 1-1/4" x 1-1/2" (2 req.)
64	7195165	Plunger Assembly, consisting of:
	7169350	Diaphragm
	7168095	Plunger
	7168079	Retainer, Housing
	7169342	O-Ring, 13/32" x 27/32"
65	9001102	O-Ring, 2-3/8" x 2-3/4"
66	7168061	Aspirator Housing
67	7168312	O-Ring, 1" x 1-1/4", single (5 req.)
	7345809	O-Ring, 1" x 1-1/4", pack of 10
68	7186598	Fill Flow Plug, Green Dot (1.0 gpm)
	7189033	Fill Flow Plug, Brown Dot (2.0 gpm)
	7189041	Fill Flow Plug, Tan Dot (3.0 gpm)
	7189059	Fill Flow Plug, Purple Dot (3.5 gpm)
69	7186580	Brine Elbow, with screen
70	7187447	Nozzle, Green Dot (.043"), Marked A
	7187455	Nozzle, Purple Dot (.055"), Marked B
	7179151	Nozzle, Gray Dot (.062"), Marked C
	7170571	Nozzle, Red Dot (.082"), Marked D

Key No.	Part No.	Description
70	7170589	Nozzle, Black Dot (.10"), Marked F
	7170597	Nozzle, Yellow Dot (.125"), Marked G
	7170602	Nozzle, Blue Dot (.156"), Marked H
	7170610	Nozzle, Orange Dot (.19"), Marked J
	7170628	Nozzle, White Dot (.219"), Marked K
	7170636	Nozzle, Green Dot (.25"), Marked M
71	7186572	O-Ring, 3/4" x 1" (3 req.)
72	7180788	Retainer Clip (5 req.)
73	7015852	Pin
74	7169180	Clip
75	7187421	Venturi, Green Dot, Marked A, 2-5/8" long
	7187439	Venturi, Purple Dot, Marked B
	7179169	Venturi, Gray Dot, Marked C
	7168100	Venturi, Red Dot, Marked D
	7169203	Venturi, Black Dot, Marked F
	7169211	Venturi, Yellow Dot, Marked G
	7169229	Venturi, Blue Dot, Marked H
	7169237	Venturi, Orange Dot, Marked J
	7169245	Venturi, White Dot, Marked K
	7169253	Venturi, Green Dot, Marked M, 2-3/8" long
76	7197206	O-Ring, 11/16" x 13/16"
77	7169326	Sleeve, Small
78	7187463	Flow Plug, Light Blue Dot (.4 gpm)
	7187413	Flow Plug, Blue Dot (.6 gpm)
	7169570	Flow Plug, Orange Dot (.8 gpm)
	7169588	Flow Plug, Green Dot (1.0 gpm)
	7169596	Flow Plug, Yellow Dot (1.2 gpm)
79	7169376	Screen, Nozzle/Venturi (2 req.)
80	7174486	End Plug
81	7169839	O-Ring, 1/2" x 3/4"
82	7169392	Flanged Bushing
83	7288138	Mounting Bracket
84	7173804	Screw, #10-32 x 1/2" (6 req.)
85	7169130	Crossbar, Bottom
86	7169122	Crossbar, Top
87	7170563	Slot Follower, Rectangular
88	7280318	Piston Assembly (includes piston rod)
89	7218329	Valve Body

continued on next page

REPAIR PARTS - 2" VALVE (continued)

Key No.	Part No.	Description
90	7168045	Aspirator Plug (2 req. on filters)
91	1289000	U-Pin (4 req.)
92	7169538	Steel Ring, Retainer
93	7169261	Retaining Plate, Front
94	7180576	Plug, DFP Plate
95	7169279	Retaining Plate, Back
96	7169334	Sleeve, Large
97	7169693	Flow Plug, Blue (5.0 gpm)
	7169708	Flow Plug, Red (6.0 gpm)
	7169716	Flow Plug, Brown (7.0 gpm)
	7169724	Flow Plug, Green (8.0 gpm)
	7169732	Flow Plug, Tan (9.0 gpm)
	7169740	Flow Plug, Red Dot (12 gpm)
	7169758	Flow Plug, Black (15 gpm)
7169774	Flow Plug, White Dot (20 gpm)	
98	7394052	Solenoid Wiring, 1-Switch Systems
■	7169871	Solenoid Wiring, 2-Switch Systems

Key No.	Part No.	Description
99	7169287	O-Ring, 3" x 3-1/4"
100	7211995	Venturi Plug
	7170327	O-Ring, 5/8" x 13/16"
OPTIONAL ACCESSORIES		
101	7362225	External No Hard Water Bypass Solenoid Valve, DC
■	7205172	Switch Kit, for above solenoid valve
102	7229443	No Hard Water Bypass Plug ●
103	7093509	O-Ring, 1.6" x 2" ●
104	7192769	Snap Ring ●
■	7289126	Filter Kit, 2" Valve, includes 1 ea. of Key Nos. 50, 51, 90, 92, 93 & 95; 2 ea. of Key Nos. 67, 72 & 91; 3 ea. of Key No. 76 & 94; & 2 ea. of 12 gpm, 15 gpm & 20 gpm Flow Plugs (see Key No. 97)

■ Not illustrated.

● Parts to be used in piston of multiple tank valve only.

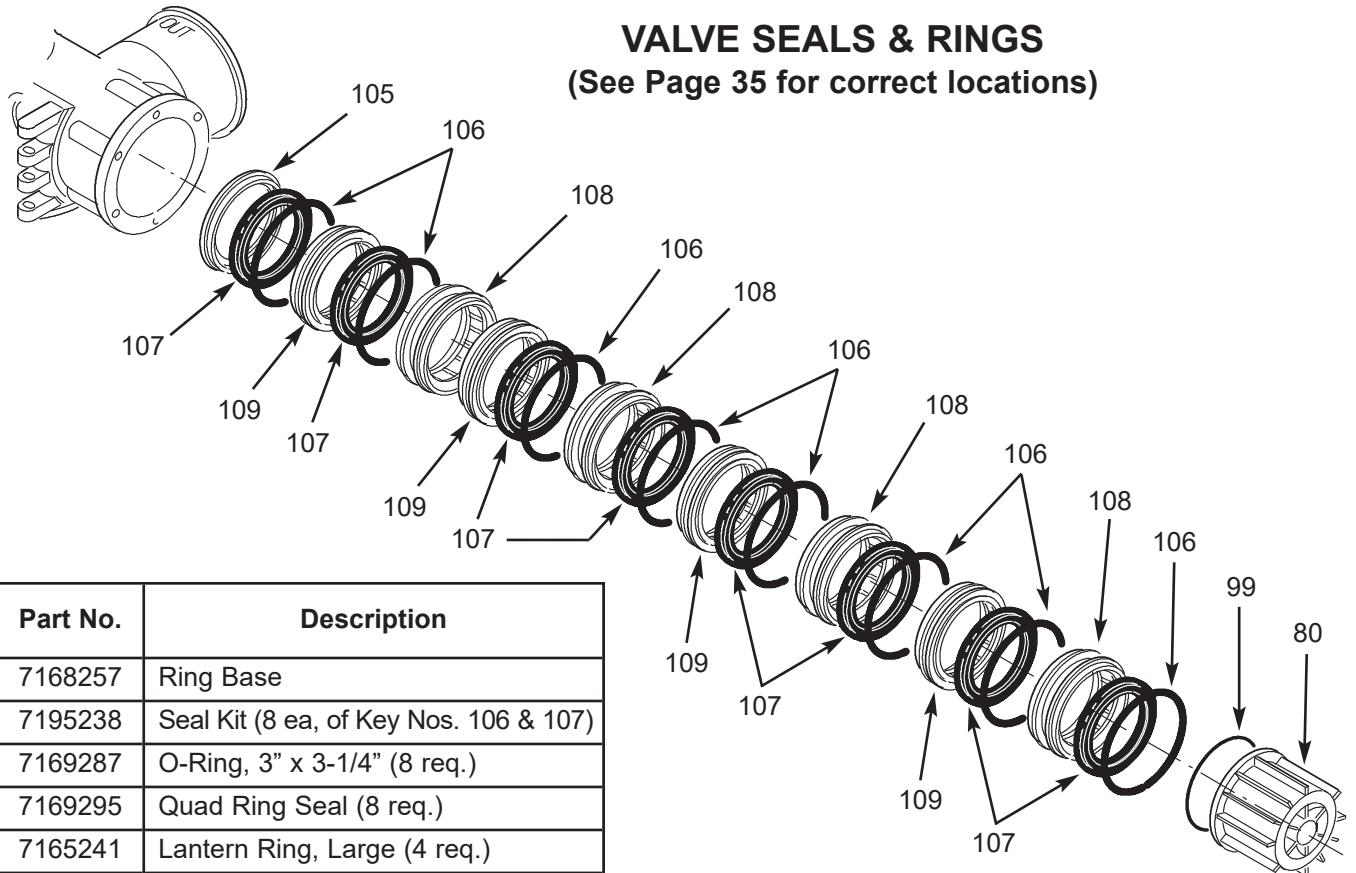

VALVE SEALS & RINGS (See Page 35 for correct locations)

Key No.	Part No.	Description
105	7168257	Ring Base
-	7195238	Seal Kit (8 ea. of Key Nos. 106 & 107)
106	7169287	O-Ring, 3" x 3-1/4" (8 req.)
107	7169295	Quad Ring Seal (8 req.)
108	7165241	Lantern Ring, Large (4 req.)
109	7165259	Lantern Ring, Small (4 req.)
-	7345825	Rebuild Kit, 2" Valve (includes Key Nos. 105-109, 99 & 81)

REPAIR PARTS - DRIVE MECHANISM & HOUSING

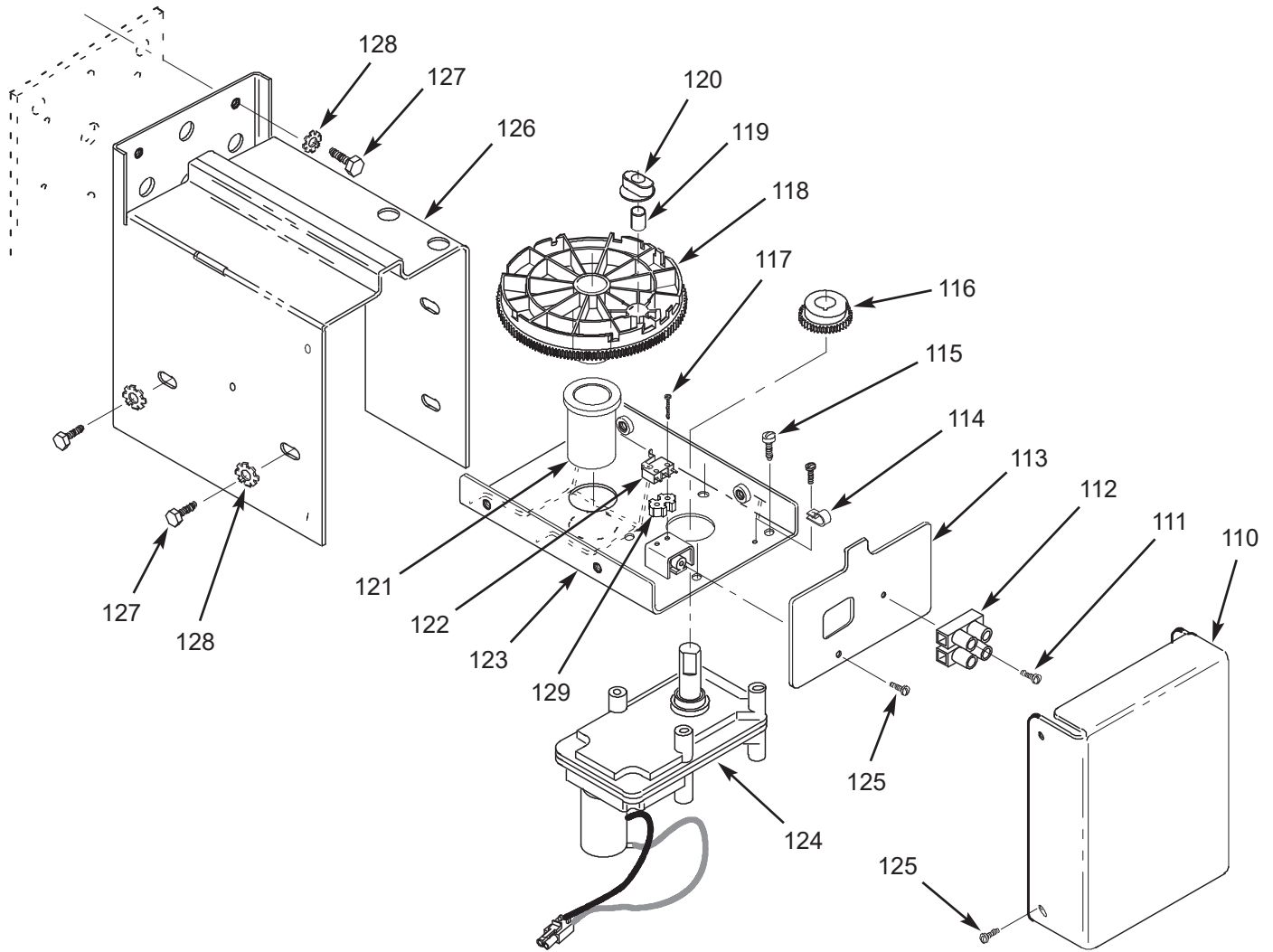

Key No.	Part No.	Description
110	7288162	Wire Cover
111	9006030	Screw, #6-20 x 5/8"
112	7176098	Base Flat Strip
113	7343352	Guard Plate
114	7187879	Strain Relief
115	7191349	Screw, #10-32 x 1/2" (3 req.)
116	7169855	Pinion
117	7174004	Screw, #2 x 5/8" (2 req.)
118	7172785	Cam & Gear (includes Key No. 119)
119	7172913	Drive Pin
120	7169520	Slot Follower
121	7169407	Bearing, Flanged

Key No.	Part No.	Description
122	7169863	Micro Switch, single
	7345817	Micro Switch, pack of 4
123	7343344	Inner Bracket
■	7179177	Decal, Cam Position
124	7281283	Motor
125	7190759	Screw, #6-32 x 3/8" (5 req.)
126	7288154	Outer Bracket
127	0900296	Screw, 1/4-20 x 5/8" (8 req.)
128	7151496	Lockwasher (8 req.)
129	7394044	Spacer (1-Switch Systems only)
-	7336517	Drive Assembly, for 1- or 2-Switch Systems (includes Key Nos. 113, 115-118 & 120-124)

■ Not illustrated.

LIMITED WARRANTY

Warrantor: EcoWater Systems LLC, P.O. Box 64420, St. Paul, MN 55164-0420

Warrantor guarantees to the original purchaser when the product is purchased from an authorized dealer, and when installed and maintained in accordance with the instructions, that:

for a period of TEN (10) YEARS from the date the product is delivered, the FIBERGLASS RESIN/MINERAL TANK will not rust, corrode, leak, burst, or in any other manner, fail to perform in accordance with its written specifications (moisture barrier is not guaranteed) and that,

for a period of THREE (3) YEARS from the date the product is delivered, the SALT TANK will not rust, corrode, leak, burst, or in any other manner, fail to perform in accordance with its written specifications and that,

for a period of THREE (3) YEARS from the date the product is delivered, the ELECTRONIC FACEPLATE will be free of defects in materials and workmanship and will perform in accordance with its written specifications, and that,

for a period of ONE (1) YEAR from the date the product is delivered, ALL OTHER PARTS will be free of defects in materials and workmanship and will perform in accordance with their written specifications.

If, during such respective period, a part proves, after inspection by Warrantor, to be defective, Warrantor will, at its sole option repair or replace that part at no charge, other than normal shipping, installation or service charges. If a repair or replacement part is unavailable, Warrantor may refund the original purchase price.

General Provisions

The above warranties are effective provided the water softener is operated at water pressures not exceeding 125 psi (8.8 kg/cm²), and at water temperatures not exceeding 100°F (38°C); provided further that the water softener is not subject to abuse, misuse, alteration, neglect, freezing, accident or negligence; and provided further that the water softener is not damaged as the result of any force of nature such as, but not limited to, flood, hurricane, tornado or earthquake.

The limited warranty does not cover damage due to: (a) transportation, (b) storage, (c) improper use, (d) failure to follow the product instructions or to perform any preventive maintenance, (e) modifications, (f) unauthorized repair, (g) normal wear and tear, or (h) external causes such as accidents, abuse, or other actions or events beyond Warrantor's reasonable control. Use of aftermarket, used, or non-manufacturer provided parts will void all warranties. Warranty does not cover failures due to improper product installation. Warrantor is excused if failure to perform its warranty obligations is the result of strikes, government regulation, materials shortages, or other circumstances beyond its control.

THERE ARE NO WARRANTIES ON THE WATER SOFTENER BEYOND THOSE SPECIFICALLY DESCRIBED ABOVE. ALL IMPLIED WARRANTIES, INCLUDING ANY IMPLIED WARRANTY OF MERCHANTABILITY OR OF FITNESS FOR A PARTICULAR PURPOSE, ARE DISCLAIMED TO THE EXTENT THEY MIGHT EXTEND BEYOND THE ABOVE PERIODS. THE SOLE OBLIGATION OF WARRANTOR UNDER THESE WARRANTIES IS TO REPLACE OR REPAIR THE COMPONENT OR PART WHICH PROVES TO BE DEFECTIVE WITHIN THE SPECIFIED TIME PERIOD, AND WARRANTOR IS NOT LIABLE FOR CONSEQUENTIAL OR INCIDENTAL DAMAGES. NO DEALER, AGENT, REPRESENTATIVE, OR OTHER PERSON IS AUTHORIZED TO EXTEND OR EXPAND THE WARRANTIES EXPRESSLY DESCRIBED ABOVE.

Some states do not allow the exclusion or limitation of incidental or consequential damages, so the above limitation or exclusion may not apply to you. This warranty gives you specific legal rights, and you may have other rights which vary from state to state. This warranty applies to consumer-owned installations only.