

Membrane System User Manual

ECO – Series



ECO – 8000 SERIES PICTURED

This page intentionally
left blank

TABLE OF CONTENTS

INTRODUCTION	4
SAFETY	5
FEEDWATER AND OPERATION SPECIFICATIONS.....	6
REJECTION, RECOVERY AND FLOW RATES	7
SYSTEM REQUIREMENTS AND OPERATION GUIDELINES	8
ELECTRICAL.....	9
MEMBRANE ELEMENTS	10
SYSTEM IDENTIFICATION	11
MEMBRANE INSTALLATION, REMOVAL AND REPLACEMENT	13
SYSTEM PURGING	16
INITIAL START-UP	17
OPERATING DO'S AND DON'TS.....	18
RO SHUT-DOWN PROCEDURE	18
PRODUCT SPECIFICATIONS.....	19
SYSTEM OPERATING LIMITS.....	20
OPERATION AND MAINTENANCE.....	21
PUMP THROTTLE VALVE	22
FLUSHING THE SYSTEM	23
PREPARING UNIT FOR STORAGE AND SHIPMENT	24
TROUBLESHOOTING	25
OPERATING LOG	27
TEMPERATURE CORRECTION FACTORS FOR MEMBRANE	28
SERVICE ASSISTANCE.....	29
SYSTEM DRAWINGS.....	30
ELECTRICAL SCHEMATIC.....	32
SYSTEM WARRANTY.....	33

INTRODUCTION

Your ECO – Series Reverse Osmosis System is a durable piece of equipment which, with proper care, will last for many years. This User Manual outlines installation, operation, maintenance and troubleshooting details vital to the sustained performance of your system.

If your system is altered at the site of operation, or if the feedwater conditions change, please contact your local dealer or distributor to determine the proper recovery for your application.

IN ORDER TO MAINTAIN THE MANUFACTURER'S WARRANTY, AN OPERATING LOG MUST BE MAINTAINED AND COPIES WILL NEED TO BE SENT TO YOUR LOCAL DEALER OR DISTRIBUTOR FOR REVIEW.

PRIOR TO OPERATING OR SERVICING THE REVERSE OSMOSIS SYSTEM, THIS USER MANUAL MUST BE READ AND FULLY UNDERSTOOD. KEEP THIS AND OTHER ASSOCIATED INFORMATION FOR FUTURE REFERENCE AND FOR NEW OPERATORS OR QUALIFIED PERSONNEL NEAR THE SYSTEM.

SAFETY

The Safety section of this User Manual outlines the various safety headings used throughout this manual's text and are enhanced and defined below:



CAUTION: INDICATES STATEMENTS THAT ARE USED TO IDENTIFY CONDITIONS OR PRACTICES THAT COULD RESULT IN EQUIPMENT OR OTHER PROPERTY DAMAGE.



WARNING: INDICATES STATEMENTS THAT ARE USED TO IDENTIFY CONDITIONS OR PRACTICES THAT COULD RESULT IN INJURY OR LOSS OF LIFE. FAILURE TO FOLLOW WARNINGS COULD RESULT IN SERIOUS INJURY OR EVEN DEATH.



DO NOT, UNDER ANY CIRCUMSTANCES, REMOVE ANY CAUTION, WARNING OR OTHER DESCRIPTIVE LABELS FROM THE SYSTEM.



PLEASE READ THE ENTIRE MANUAL BEFORE PROCEEDING WITH THE INSTALLATION AND START-UP. FAILURE TO FOLLOW INSTRUCTIONS OR OPERATING PARAMETERS MAY LEAD TO THE PRODUCT'S FAILURE, WHICH CAN CAUSE PROPERTY DAMAGE AND/OR PERSONAL INJURY.

- DO NOT USE WHERE THE WATER IS MICROBIOLOGICALLY UNSAFE OR OF UNKNOWN QUALITY WITHOUT ADEQUATE DISINFECTION BEFORE OR AFTER THE SYSTEM.
- PRE-TREATMENT MUST BE SUFFICIENT TO ELIMINATE CHEMICALS, ORGANICS OR INORGANICS THAT COULD ATTACK THE MEMBRANE MATERIAL.
- ALWAYS TURN OFF THE UNIT, SHUT OFF THE FEEDWATER AND DISCONNECT THE ELECTRICAL POWER BEFORE WORKING ON THE UNIT.
- NEVER ALLOW THE PUMP TO RUN DRY.
- NEVER START THE PUMP WITH THE CONCENTRATE OR GLOBE /THROTTLE VALVE CLOSED.
- NEVER ALLOW THE UNIT TO FREEZE OR OPERATE WITH A FEEDWATER TEMPERATURE ABOVE 85°F.

FEEDWATER AND OPERATION SPECIFICATIONS

Nothing has a greater effect on a reverse osmosis system than the feedwater quality.



IT IS VERY IMPORTANT TO MEET THE MINIMUM FEEDWATER REQUIREMENTS. FAILURE TO DO SO WILL CAUSE THE MEMBRANES TO FOUL AND VOID THE MANUFACTURER'S WARRANTY.

OPERATING LIMITS*

Operating Parameters:

Feed Temperature	40 – 85°F
System Inlet Pressure	45 – 85 psi
Maximum Operating Pressure (at 77°F)	200 psi

Feedwater Requirements:

Maximum SDI Rating	< 3
Maximum Turbidity	1 NTU
Maximum Free Chlorine and/or Chloramines	0 PPM
PH (continuous)	2 – 11
PH (cleaning for 30 minutes)	1 – 13

*If any of the feedwater parameters are not within the limits given, consult your local dealer or distributor for assistance.



HIGHER TDS AND/OR LOWER TEMPERATURES WILL REDUCE THE SYSTEM'S PRODUCTION.

REJECTION, RECOVERY AND FLOW RATES

ECO – Series Reverse Osmosis Systems are designed to produce permeate water at the capacities indicated by the suffix in the system's name under the conditions listed above. For example, the ECO – 2000 system produces 2,000 gallons per day of permeate water at the listed operating test conditions.

The amount of total dissolved solids (TDS) rejected by the membrane is expressed as a percentage. For example, a 98.5% rejection rate means that 98.5% of total dissolved solids do not pass through the membrane. To calculate the percentage of rejection, use the following formula:

$$\% \text{ Rejection} = [(\text{Feed TDS} - \text{Product TDS}) / \text{Feed TDS}] \times 100$$

Example:

$$98.5\% = [(550 - 8.25) / 550] \times 100$$

ALL TDS FIGURES MUST BE EXPRESSED IN THE SAME UNITS, TYPICALLY PARTS PER MILLION (PPM) OR MILLIGRAMS PER LITER (MG/L).

ECO – Series Reverse Osmosis Systems are designed to reject up to 98.5% NaCl, unless computer projections have been provided or stated otherwise.

The amount of permeate water recovered for use is expressed as a percentage. To calculate the percentage of recovery, use the following formula:

$$\% \text{ Recovery} = (\text{Product Water Flow Rate} / \text{Feed Water Flow Rate}) \times 100$$

Example:

$$50\% = (1.02 / 2.04) \times 100$$

ALL FLOW RATES MUST BE EXPRESSED IN THE SAME UNITS, TYPICALLY GALLONS PER MINUTE (GPM).

SYSTEM REQUIREMENTS AND OPERATION GUIDELINES

PLUMBING

The membranes and high pressure pumps used on ECO – Series systems require a continuous flow of water with a minimum feed pressure of 45 psi, not to exceed 85 psi.

FEEDWATER CONNECTION

1. Locate the 3/4" FNPT solenoid valve feed water inlet.
2. Attach the inlet piping to the 3/4" FNPT solenoid valve feedwater inlet.
3. Be certain that all of the components of the feedwater are soluble at the concentrations attained in the system.



FEED LINE MUST BE A MINIMUM OF 3/4" INCH.

PERMEATE (PRODUCT WATER) CONNECTION

Locate the 1/2" QC connector after the check valve on the outlet of the flow meter labeled "permeate", and attach to storage tank. Ensure that the permeate water can flow freely with no backpressure. Backpressure can cause irreversible damage to the membrane elements. The permeate line can be run to the holding tank with PVC fittings or other FDA approved materials. This is so the material being used does not dissolve into the permeate water.

THE PH OF THE REVERSE OSMOSIS PERMEATE WATER WILL TYPICALLY BE 1 OR 2 PH UNITS LOWER THAN THE FEEDWATER PH. A LOW PH CAN BE VERY AGGRESSIVE TO SOME PLUMBING MATERIALS SUCH AS COPPER PIPING.

CONCENTRATE (WASTE WATER) CONNECTION

Locate the 1/2" QC outlet on the flow meter labeled "concentrate" and attach to a drain. Run the concentrate line to an open drain in a free and unrestricted manner (no backpressure).



ANY RESTRICTIONS OR BLOCKAGE IN THE DRAIN LINE CAN CAUSE BACKPRESSURE, WHICH WILL INCREASE THE SYSTEM'S OPERATING PRESSURE. THIS CAN RESULT IN DAMAGE TO THE SYSTEM'S MEMBRANES AND COMPONENTS.

ELECTRICAL

The motor used on the ECO – Series systems are pump and motor combinations. The motor is available in 110/220 VAC 60 Hertz 1 Phase. Each ECO – Series system is equipped with an eight-foot electrical cord. The 110V systems include a three-pronged electrical plug.

Ensure that the electrical circuit supplying the system is compatible with the requirements of the specific ECO – Series model you are installing.



IT'S RECOMMENDED THAT A LICENSED ELECTRICIAN WIRE YOUR SYSTEM IN ACCORDANCE WITH LOCAL AND NATIONAL ELECTRICAL CODES (NEC).



TO REDUCE THE RISK OF ELECTRICAL SHOCK, THE INCOMING POWER SUPPLY MUST INCLUDE A PROTECTIVE EARTH GROUND.

ECO – Series systems are typically controlled with a liquid level switch in a storage tank. The liquid level switch turns the system on when the water level in the tank drops, and off when the tank is full. Liquid level switches can be obtained by your local dealer or distributor. If a liquid level switch is to be used, install it at this time.

PRE-FILTRATION

ECO – Series systems are supplied with a 5-micron sediment filter. Change the cartridge once a month or when a 10 – 15 psi differential exists between the two pre-filter gauges.



THE SYSTEM MUST BE OPERATED ON FILTERED WATER ONLY.

PUMP

The pump type used on the ECO – Series systems is multi-stage centrifugal stainless steel. If any damage occurs to your system's pump, a re-build kit may be available. Contact your local dealer or distributor and inform them of your system and pump model.

MOUNTING

The free standing system should be bolted down or securely fastened in compliance with local regulation standards. The system comes standard with a rubber bumper kit. Casters and levelers are available but optional.

MEMBRANE ELEMENTS

The ECO – Series Reverse Osmosis Systems are equipped with Thin Film Composite (TFC) HF5 – Ultra Low Energy Membranes unless otherwise specified. General membrane element performance characteristics are listed below.

HF5 – Ultra Low Energy Membranes

- **Membrane Type:** Polyamide Thin – Film Composite
- **Maximum Operating Temperature:** 113°F (45°C)
- **Maximum Operating Pressure:** 400 psi (27.58 bar)
- **pH Range, Continuous Operation*:** 2 – 11
- **pH Range, Short Term Cleaning (30 Min.):** 1 – 13
- **Maximum Feed Silt Density Index (SDI):** 5
- **Chlorine Tolerance:** 0 ppm
- **Maximum Feed Flow Rate (gpm):** 2.5" = 6; 4.0" = 16

*Maximum temperature for continuous operations above pH10 is 95°F (35°C).

Product Specifications				
Part Number	Description	Applied Pressure psi / bar	Permeate Flow Rate gpd / m3/d	Nominal Salt Rejection (%)
208125	HF5 – 2514	80 / 5.2	225 / 0.85	98.5%
208083	HF5 – 2521	80 / 5.2	400 / 1.51	98.5%
208084	HF5 – 2540	80 / 5.2	850 / 3.22	98.5%
200392	HF5 – 4014	80 / 5.2	600 / 2.27	98.5%
200393	HF5 – 4021	80 / 5.2	1000 / 3.79	98.5%
200394	HF5 – 4040	80 / 5.2	2500 / 9.46	98.5%

Warranty Evaluation Test Conditions: Permeate flow and salt rejection based on the following test conditions – 550 ppm, filtered and dechlorinated municipal tap water, 77°F / 25°C, 15% recovery and the specified operating pressure. Minimum salt rejection is 96%. Permeate flows for warranty evaluation may vary +/-20%. Maximum pressure drops at 13 psi / 0.9 bar.

Dimensions inch / mm				
Description	A	B	C	D
HF5 – 2514	14 / 355.6	1.1 / 27.94	0.75 / 19.05	2.40 / 60.96
HF5 – 2521	21 / 533.4	1.1 / 27.94	0.75 / 19.05	2.40 / 60.96
HF5 – 2540	40 / 1016.0	1.1 / 27.94	0.75 / 19.05	2.40 / 60.96
HF5 – 4014	14 / 355.6	1.1 / 27.94	0.75 / 19.05	3.95 / 100.3
HF5 – 4021	21 / 533.4	1.1 / 27.94	0.75 / 19.05	3.95 / 100.3
HF5 – 4040	40 / 1016.0	1.1 / 27.94	0.75 / 19.05	3.95 / 100.3

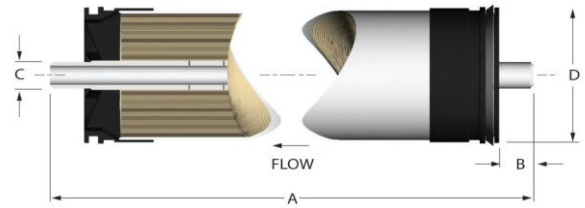

Proper start-up of reverse osmosis water treatment systems is essential to prepare the membranes for operating service and to prevent membrane damage due to overfeeding or hydraulic shock. Before initiating system start-up procedures, membrane pretreatment, loading of the membrane elements, instrument calibration and other system checks should be completed.

Avoid any abrupt pressure or cross-flow variations on the spiral elements during start-up, shutdown, cleaning or other sequences to prevent possible membrane damage. During start-up, a gradual change from a standstill to operating state is recommended as follows:

- Feed pressure should be increased gradually over a 30 – 60 second time frame.
- Cross-flow velocity at set operating point should be achieved gradually over 15 – 20 seconds.
- Permeate obtained from first hour of operation should be discarded.
- Maximum pressure drops across an entire pressure vessel (housing) is 30 psi / 2.1 bar.
- Avoid static permeate-side backpressure at all times.

Under certain conditions, the presence of free chlorine, chloramines and other oxidizing agents will cause premature membrane failure. Since oxidation damage is not covered under warranty, the manufacturer recommends removing all oxidizing agents by pretreatment prior to membrane exposure. Please contact the manufacturer or your supplier for more information.

Do not use this initial permeate for drinking water or food preparation. Keep elements moist at all times after initial wetting. To prevent biological growth during prolonged system shutdowns, it is recommended that membrane elements be immersed in a preservative solution. Rinse out the preservative before use. For membrane warranty details, please contact the manufacturer or your supplier for more information.

If operating limits and guidelines given in this product specification sheet are not strictly followed, the warranty will be null and void. The customer is fully responsible for the effects of incompatible chemicals and lubricants on elements. Use of any such chemicals or lubricants will void the warranty. These membranes may be subject to drinking water application restrictions in some countries: please check the application status before use and sale. The use of this product in and of itself does not necessarily guarantee the removal of cysts and pathogens from water. Effective cyst and pathogen reduction is dependent on the complete system design and on the operation and maintenance of the system.

No freedom from infringement of any patent owned by the manufacturer or others is to be inferred. Because use conditions and applicable laws may differ from one location to another and may change with time, customer is responsible for determining whether products and the information in this document are appropriate for customer's use and for ensuring that customer's workplace and disposal practices are in compliance with applicable laws and other governmental enactments. The claims made may not have been approved for use in all countries. The manufacturer assumes no obligation or liability for the information in this document. **NO WARRANTIES ARE GIVEN; ALL IMPLIED WARRANTIES OF MERCHANTABILITY OR FITNESS FOR A PARTICULAR PURPOSE ARE EXPRESSLY EXCLUDED.**

SYSTEM IDENTIFICATION

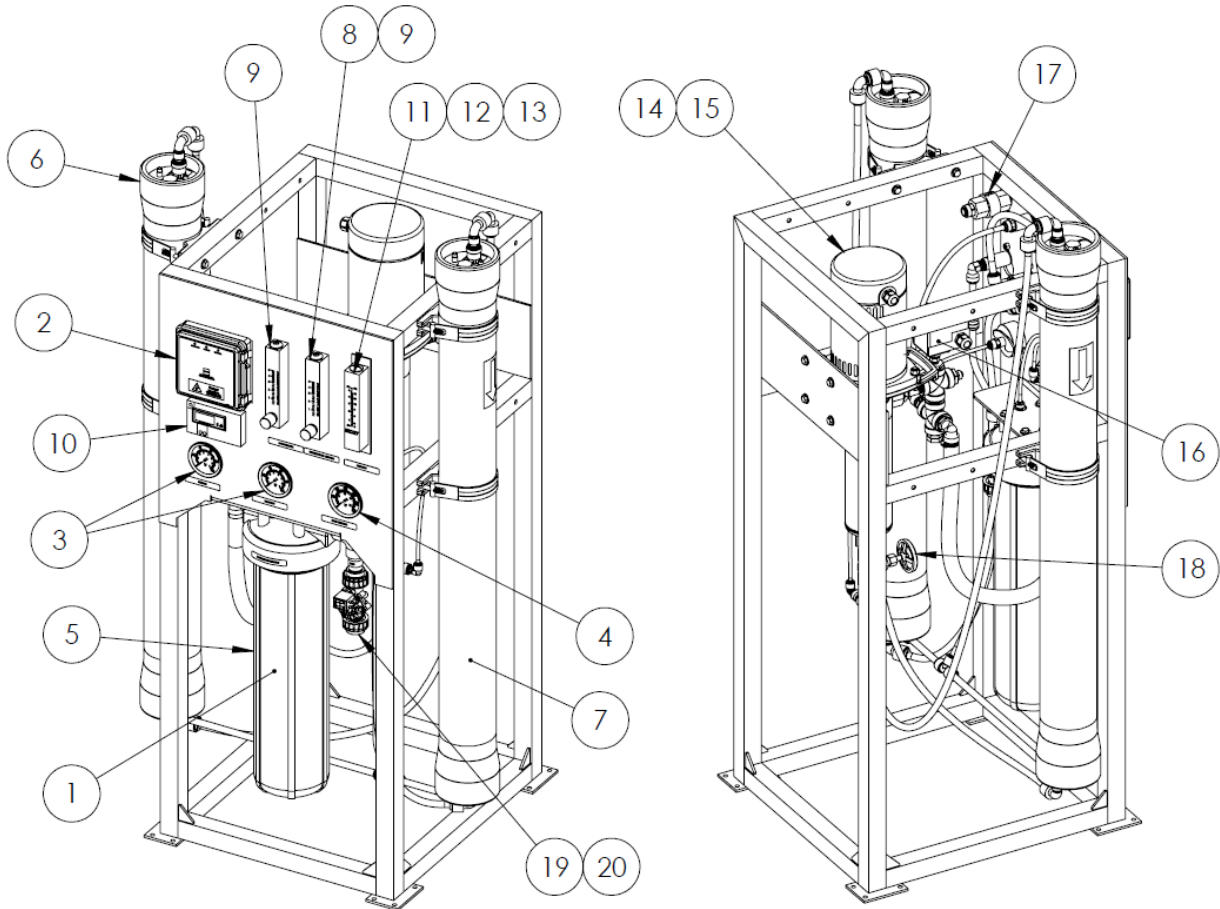

Figure 1

SYSTEM IDENTIFICATION

ITEM NO.	DESCRIPTION	PART NUMBER	MODELS
1	CARTRIDGE, SEDIMENT, POLYPRO, 4.5" X 20", 5 MIC	200640	2000-8000
2	CONTROLLER, COMPUTER, C-26, 110V/220V, 1PH, 50/60HZ	210355	2000-8000
3	GAUGE, BKM, GLY FILL, 0-100 PSI/BAR, 2.5" DIA, 1/4" MNPT, AXEON	204165	2000-8000
4	GAUGE,PM,GLY FILL,0-300 PSI/BAR,2.5 DIA,SS,1/4"MNPT,AXEON	203511	2000-8000
5	HOUSING, FILTER, BLK/GRY, 4.5" X 20", SGL O-RING, NPR, 3/4" FNPT, AXEON	207289	2000-8000
6	HOUSING, MEMBRANE, FRP-300E, 4040, 1/2" P X 3/4" C FNPT, AXEON	208419	2000-8000
7	MEMBRANE, HF5, 4040, DRY, AXEON	200394	2000-8000
8	METER, FLOW, PM, 0.2-2 GPM, SS VALVE, 1/2" MNPT X 1/2" MNPT, AXEON	205103	2000
9	METER, FLOW, PM, 1-5 GPM, SS VALVE, 1/2" MNPT X 1/2" MNPT, AXEON	205104	2000-8000
10	METER, TDS, INLINE, FRONT PANEL	203385	2000-8000
11	METER, FLOW, PM, 0.2-2 GPM, 1/2" MNPT x 1/2" MNPT, ABS FTG, AXEON	200897	2000
12	METER,FLOW,PM,1-5 GPM,1/2" MNPT X 1/2" MNPT	200898	4000, 6000
13	METER, FLOW, PM, 1-10 GPM, 1" MNPT x 1" MNPT, AXEON	200899	8000
14	PUMP, BOOSTER, 1/2-3/4HP, 115/230V, 1PH, 7FBT05S4, FRANKLIN	207129	2000, 4000
15	PUMP, BOOSTER, 1 - 1 1/2HP, 115/230V, 1PH, 7FBT1S4, FRANKLIN	207130	6000, 8000
16	SWITCH, PRESSURE, LOW, N/O 15-30, 1/4 FNPT	200906	2000-8000
17	VALVE, CHECK, PVC, 1/2" FNPT X 1/2" FNPT	200965	2000-8000
18	VALVE, GLOBE, SS, 3/4" FNPT	200994	2000-8000
19	VALVE, SOLENOID, 2-WAY, COMPOSITE, 220V, 3/4" FNPT, ASCO	207088	6000, 8000
20	VALVE, SOLENOID, 2-WAY, COMPOSITE, 120V, 3/4"FNPT, ASCO	207472	2000, 4000

MEMBRANE INSTALLATION, REMOVAL AND REPLACEMENT

Installation and replacing membranes in the pressure vessels is an easy process if you have the proper information and tools at hand. Please refer to the following instructions when removing and replacing membrane elements:



ALL PRESSURE GAUGES MUST READ ZERO BEFORE PROCEEDING. BEFORE ATTEMPTING, DISCONNECT THE POWER FROM THE SYSTEM AND BLEED ALL WATER PRESSURE FROM THE SYSTEM.

1. Remove the end plugs from the top of the pressure vessels. This is done by removing the two locking crescents using a #5 Allen wrench; the end plugs should then freely slide out of the pressure vessel.
2. Remove the replacement membrane element(s) from the shipping box; the membrane(s) should be contained within a plastic bag.

WEAR GLOVES FOR THE FOLLOWING STEPS IN ORDER NOT TO CONTAMINATE THE MEMBRANE.

3. Cut the bag open as close as possible to the seal at one end of the bag, so the bag may be re-used if necessary.
4. Make sure that all parts are clean and free from dirt. Examine the brine seal, and permeate tube for nicks or cuts. Replace the o-rings or brine seal on the end plug if damaged.
5. Flow directions should be observed for installation of each element into their respective pressure vessels.

REPLACING THE MEMBRANE ELEMENT:



THE BRINE SEAL MUST BE IN THE CORRECT POSITION FOR EACH MEMBRANE ELEMENT HOUSINGS. THE BRINE SEAL IS A RUBBER SEAL THAT PROTRUDES ON ONE SIDE OF THE MEMBRANE AND IS ALWAYS ON THE FEED SIDE OF THE MEMBRANE ELEMENT. FOR ECO – SERIES REVERSE OSMOSIS SYSTEMS THE BRINE SEAL SHOULD BE ON THE TOP SIDE OF THE MEMBRANE HOUSINGS.

1. Remove one membrane element at a time from the pressure vessels, from the top of each housing. Long nose pliers may be necessary to pull the old membrane element out of the membrane element housing.
2. Lubricate the brine seal and o-rings with a non-petroleum based lubricant, such as Dow Corning® 111. Do not use a petroleum-based lubricant.
3. Install membranes with brine seal location depicted in. (Figure 2, Page 15)
4. With a smooth and constant motion, push the membrane element into the housing so the brine seal enters the housing without coming out of the brine seal groove.
5. Re-install the end plugs by gently twisting the end cap, while pushing it onto the housing. Ensure that you do not pinch or fatigue any o-rings while re-installing the end plug. Push the end plug on until the outer diameter of the plug is flush with the outer diameter of the pressure vessel.
6. Insert the two locking crescents until they are fully seated. Subsequently fasten using a #5 Allen wrench.
7. Reconnect any fittings that may have been disconnected when the membrane pressure vessels were disassembled.
8. To start-up the system, please refer to the Initial Start-Up section of this User Manual.

THE MEMBRANES MUST BE FLUSHED FOR AT LEAST 30 MINUTES TO REMOVE THE PRESERVATIVE FROM THE MEMBRANE. DISCARD ALL OF THE PERMEATE, WHICH IS PRODUCED DURING THE FLUSH PERIOD.



ECO – 2000

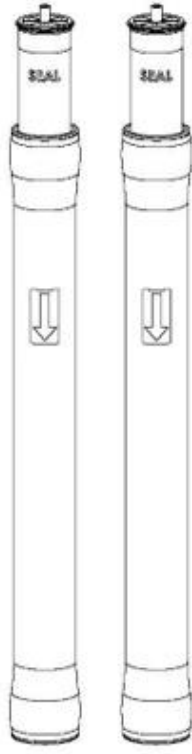

ECO – 4000

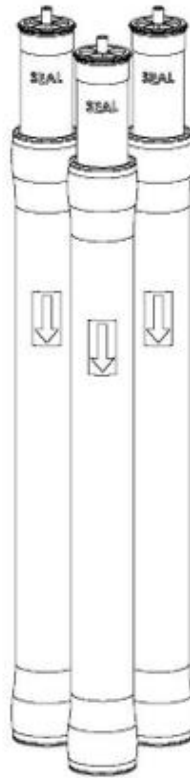

ECO – 6000

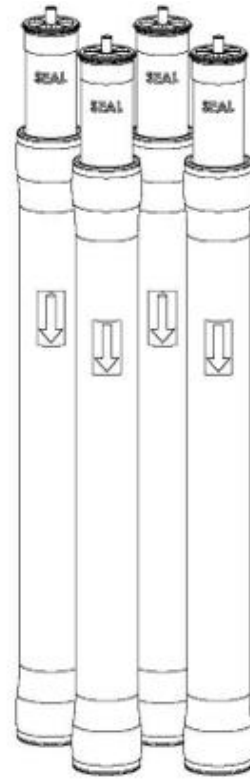

ECO – 8000

Figure 2 View from the back of ECO – Series Reverse Osmosis Systems

SYSTEM PURGING



MAKE SURE THE SYSTEM POWER SWITCH IS IN THE OFF POSITION BEFORE BEGINNING THIS PROCEDURE.

1. Redirect permeate water to the drain for this procedure.
2. Fully open the concentrate valve by turning it counter-clockwise.
(#9, Figure 1, Page 11)
3. Fully close the concentrate recycle valve by turning it clockwise.
(#8,9, Figure 1, Page 11)
4. Fully open the throttle valve by turning it counter-clockwise.
(#18, Figure 1, Page 11; and Figure 4, Page 22)
5. Activate the manual feed flush feature by pressing and holding the power button on the C26 Controller for 5 seconds. The system will flush for 60 seconds. To end the flush before the 60 second cycle is complete, press the power button once.
6. Let the system purge until no visible bubbles appear from concentrate flow meter. It may be necessary to flush the system more than one cycle.



Figure 3

INITIAL START-UP

Carefully inspect your system before initial start-up. Check that all plumbing and electrical connections are not loose or have not come undone during shipment.

Keep the permeate water line to drain for this procedure.

1. Fully open the concentrate valve by turning it counter-clockwise.
(#9, Figure 1, Page 11)
2. Fully close the concentrate recycle valve by turning it clockwise.
(#8,9, Figure 1, Page 11)
3. Fully close the throttle valve clockwise. Once fully closed, open half a turn counter-clockwise.
(#18, Figure 1, Page 11; and Figure 4, Page 22)
4. Turn the RO system on and adjust the concentrate (waste) valve, recycle valve and the throttle valve to the designed flow and pressure.
5. Inspect the system for leaks.
6. Allow the system to run 30 minutes to flush the preservative solution from the system.
7. After 30 minutes, shut down the system.
8. Re-direct the permeate water back to the tank and then turn the system back on.
9. Record the readings daily for a week; after one week record the readings once a week.

OPERATING DO'S AND DON'TS

DO:

- Change the cartridge filters regularly.
- Monitor the system and keep a daily log.
- Run the system as much as possible on a continuous basis.
- Adjust the system recovery to the recommended value.
- Always feed the pump with filtered water.

DON'T

- Permit chlorine to enter or be present in the feedwater.
- Shut down the system for extended periods.
- Close the throttle valve completely.
- Operate the system with insufficient feed flow.
- Operate the pump dry.

RO SHUT-DOWN PROCEDURE

1. Purge system. See Purging and Initial Start-up instructions.
2. Turn off feed supply water from system.
3. Set the system power switch to the off position. Unplug the system power cord from wall.
4. When the unit is ready to restart please follow the initial start-up procedures. The permeate line should be diverted to drain for 30 minutes.

If the RO unit is to be shut down for an extended period of time, a membrane preservative should be used to preserve the membranes. See Preparing Unit for Storage or Shipment instructions.

PRODUCT SPECIFICATIONS

MODELS	ECO – 2000	ECO – 4000	ECO – 6000	ECO – 8000
Design				
Configuration	Single Pass	Single Pass	Single Pass	Single Pass
Feedwater Source [†]	TDS < 2000	TDS < 2000	TDS < 2000	TDS < 2000
System Recovery with Recycle	Up to 60%	Up to 75%	Up to 75%	Up to 75%
Rejection and Flow Rates^{††}				
Nominal Salt Rejection	98.50%	98.50%	98.50%	98.50%
Permeate Flow Rate	1.39 gpm	2.78 gpm	4.17 gpm	5.56 gpm
Concentrate Flow Rate (minimum)	3.00 gpm	3.00 gpm	3.00 gpm	3.00 gpm
Concentrate Recycle Flow Rate	Up to 2.00 gpm	Up to 5.00 gpm	Up to 5.00 gpm	Up to 5.00 gpm
Connections				
Feed Connection	3/4" FNPT	3/4" FNPT	3/4" FNPT	3/4" FNPT
Permeate Connection	1/2" QC	1/2" QC	1/2" QC	1/2" QC
Concentrate Connection	1/2" QC	1/2" QC	1/2" QC	1/2" QC
Membranes				
Membranes Per Vessel	1	1	1	1
Membrane Quantity	1	2	3	4
Membrane Size	4040	4040	4040	4040
Vessels				
Vessel Array	1	1:1	1:1:1	1:1:1:1
Vessel Quantity	1	2	3	4
Pump				
Pump Type	Multi-stage	Multi-stage	Multi-stage	Multi-stage
Motor HP	1/2 – 3/4	1/2 – 3/4	1 – 1 1/2	1 – 1 1/2
RPM at 60HZ	3450	3450	3450	3450
System Electrical				
Controller	C – 26	C – 26	C – 26	C – 26
High Voltage Service + Amp Draw	110V 1PH 60 HZ 13.4A**	110V 1PH 60 HZ 13.4A**	110V 1PH 60 HZ 10.94A**	220V 1PH 60 HZ 10.94A**
System Dimensions				
Approximate Dimensions* (L x W x H)	25" x 25" x 56"	25.5" x 30" x 56"	25.5" x 30" x 56"	25.5" x 30" x 56"
Approximate Weight	130 lbs.	140 lbs.	155 lbs.	180 lbs.

Warranty Evaluation Test Conditions: Permeate flow rates and salt rejection based on the following test conditions – 550 ppm, filtered and dechlorinated municipal tap water, 77°F / 25°C, 15% recovery, 7.0 pH and the specified operating pressure for membrane element type. Data taken after 60 minutes of operation.

* Does not include operating space requirements.

** Varies with motor manufacturer.

Operating Limits^{††}

Design Temperature	77°F	Maximum Turbidity	1
Maximum Feed Temperature	85°F	Maximum Free Chlorine (ppm)	0
Minimum Temperature	40°F	Maximum TDS (ppm)	2,000
Maximum Ambient Temperature	120°F	Maximum Hardness (gpg)	<1
Minimum Ambient temperature	40°F	Maximum PH (continuous)	11
Maximum Feed Pressure	85	Minimum PH (continuous)	2
Minimum Feed Pressure	45	Maximum PH (cleaning 30 minutes)	13
Maximum Operating Pressure	200	Minimum PH (cleaning 30 minutes)	1
Maximum SDI Rating	<3		

† Low temperatures and feedwater quality, such as high TDS levels will significantly affect the systems production capabilities and performance. Computer projections must be run for individual applications which do not meet or exceed minimum and maximum operating limits for such conditions.

†† System pressure is variable due to water conditions. Permeate flow will increase at a higher temperature and will decrease at a lower temperature.

††† Product flow and maximum recovery rates are based on feedwater conditions as stated above. Do not exceed recommended permeate flow.

Design conditions are not identical to test conditions, please contact the manufacturer or your supplier for more information.

Proper start – up of reverse osmosis water treatment systems is essential to prepare the membranes for operating service and to prevent membrane damage due to overfeeding or hydraulic shock. Before initiating system start – up procedures, membrane pretreatment, loading of the membrane elements, instrument calibration and other system checks should be completed.

Avoid any abrupt pressure or cross–flow variations on the spiral elements during start–up, shutdown, cleaning or other sequences to prevent possible membrane damage. During start–up, a gradual change from a standstill to operating state is recommended as follows:

- Feed pressure should be increased gradually over a 30 – 60 second time frame.
- Cross – flow velocity at set operating point should be achieved gradually over 15 – 20 seconds.
- Permeate obtained from first hour of operation should be discarded.
- Maximum pressure drops across an entire pressure vessel (housing) is 30 psi / 2.1 bar.
- Avoid static permeate–side backpressure at all times.

Under certain conditions, the presence of free chlorine, chloramines and other oxidizing agents will cause premature membrane failure. Since oxidation damage is not covered under warranty, the manufacturer recommends removing all oxidizing agents by pretreatment prior to membrane exposure. Please contact the manufacturer or your supplier for more information.

Do not use the initial permeate for drinking water or food preparation. Keep elements moist at all times after initial wetting. To prevent biological growth during prolonged system shutdowns, it is recommended that membrane elements be immersed in a preservative solution. Rinse out the preservative before use. For membrane warranty details, contact the manufacturer or your supplier for more information.

If operating limits and guidelines given in this product specification sheet are not strictly followed, the warranty will be null and void. The customer is fully responsible for the effects of incompatible chemicals and lubricants on elements. Use of any such chemicals or lubricants will void the warranty. These membranes may be subject to drinking water application restrictions in some countries: check the application status before use and sale. The use of this product in and of itself does not guarantee the removal of cysts and pathogens from water. Effective cyst and pathogen reduction is dependent on the complete system (solution) design and the operation and maintenance of the system.

No freedom from infringement of any patent owned by the manufacturer or others is to be inferred. Because use conditions and applicable laws may differ from one location to another and may change with time, Customer is responsible for determining whether products and the information in this document are appropriate for customer's use and for ensuring that customer's workplace and disposal practices are in compliance with applicable laws and other governmental enactments. The claims made may not have been approved for use in all countries. The manufacturer assumes no obligation or liability for the information in this document. **NO WARRANTIES ARE GIVEN; ALL IMPLIED WARRANTIES OF MERCHANTABILITY OR FITNESS FOR A PARTICULAR PURPOSE ARE EXPRESSLY EXCLUDE.**

OPERATION AND MAINTENANCE

The reverse osmosis process causes the concentration of impurities. The impurities may precipitate (come out of solution) when their concentration reaches saturation levels.



PRECIPITATION CAN SCALE OR FOUL MEMBRANES AND MUST BE PREVENTED.

Check your feedwater chemistry and pre-treat the water and/or reduce the system's recovery as required. If necessary, consult with your local dealer or distributor.

PRE-FILTER PRESSURE GAUGES

These gauges measure the feedwater pressure when it enters and exits the pre-filters. A pressure differential of 10 – 15 psi or more on the two pressure gauges indicates that the pre-filters require servicing. For example, if the inlet pressure is 45 psi, the filter should be changed when the outlet pressure is 30 psi or below.

PERMEATE (PRODUCT) FLOW METER, CONCENTRATE (WASTE) FLOW METER AND RECYCLE FLOW METER.

These flow meters indicate the flow rates of the permeate, concentrate and recycle water. The measurements, when added together, also indicate the feedwater flow rate or (total flow rate).



EXCESSIVE RECYCLING MAY CAUSE PREMATURE FOULING OR SCALING OF THE MEMBRANE ELEMENTS.

LOW PRESSURE SWITCH

The low pressure switch shuts off the system when the feedwater pressure drops below 15 psi, preventing damage to the pump. The system restarts automatically when there is a constant pressure of 35 psi or more.



IF YOU NOTICE THE PRESSURE FLUCTUATING, AND THE SYSTEM CYCLING OFF AND ON, TURN THE SYSTEM OFF AND ENSURE THAT PROPER FEED FLOW AND PRESSURE ARE AVAILABLE TO THE SYSTEM.

PUMP THROTTLE VALVE

The Pump Throttle Valve is installed as a standard feature on the ECO – Series Reverse Osmosis Systems. It provides an adjustment for pump pressure. As the feedwater temperature decreases, and/or the feedwater TDS increases, the system will require a higher operating pressure to produce the specified permeate flow.

ADJUSTING THE THROTTLE VALVE

To decrease the pressure, turn the handle clockwise. To increase the pressure, turn the handle counter clockwise. (Figure 4)

DECREASE PRESSURE

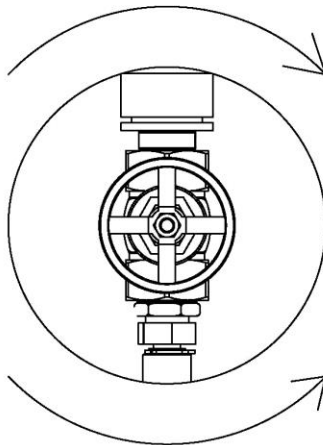

INCREASE PRESSURE

Figure 4

FLUSHING THE SYSTEM

The system should be flushed weekly to remove sediment from the surface of the membranes. To manually flush the system, follow these steps:

1. The system must be operating during the flush procedure.
2. Fully open the concentrate valve by turning it counter-clockwise.
(#9, Figure 1, Page 11)
3. Allow the system to run for 10 to 20 minutes.
4. After 10 to 20 minutes, close the concentrate valve to its previous setting.
Ensure the proper concentrate flow rate is going to the drain.
5. The system is now ready to operate.

PREPARING UNIT FOR STORAGE OR SHIPMENT



PRIOR TO SHIPPING OR STORING YOUR SYSTEM, THE SYSTEM SHOULD BE CLEANED WITH AN APPROPRIATE CLEANER, FLUSHED WITH WATER AND PROTECTED FROM BIOLOGICAL ATTACK WITH AN APPROPRIATE SOLUTION FOR MEMBRANE ELEMENTS. THE MEMBRANE HOUSING(S) AND PLUMBING LINES OF THE SYSTEM MUST BE COMPLETELY DRAINED. ANY WATER REMAINING IN THE PLUMBING OF A SYSTEM MAY FREEZE, CAUSING SERIOUS DAMAGE.

Preparing system for storage:

1. Completely immerse the elements in the membrane housings using 2% M-100 solution*, venting the air outside of the pressure vessels. Use the overflow technique: circulate the M-100 solution in such a way that the remaining air in the system is minimized after the recirculation is completed. After the pressure vessel is filled, the M-100 solution should be allowed to overflow through an opening located higher than the upper end of the highest pressure vessel being filled. *For cold weather/winter storage add 20% by weight Polyglycol to the 2% M-100 solution. Add Polyglycol AFTER the 2% M-100 solution has been mixed.
2. Separate the preservation solution from the air outside by closing all valves. Any contact with oxygen will oxidize the M-100 solution.
3. Check the pH once a week. When the pH becomes 3 or lower, change the preservation solution.
4. Repeat this process at least once a month.

During the shut-down period, the plant must be kept frost-free, or the ambient temperature must not exceed 120°F (48.8°C) ambient.

Preparing unit for shipment:

1. Disconnect the inlet, concentrate, pre-filter, and permeate plumbing.
2. Drain all water from the pre-filter cartridge housings by unscrewing the housings, removing the pre-filter cartridges, and drain the water from the housings.
3. Disconnect the tubing from the connectors on the permeate and concentrate inlets and outlets.
4. Fully open the concentrate valve.
5. Drain the flow meters.

Allow the system to drain for a minimum of eight hours or until the opened ports quit dripping.

AFTER DRAINING IS COMPLETE, RECONNECT ALL OF THE PLUMBING.

TROUBLESHOOTING

SYMPTOMS	POSSIBLE CAUSES	CORRECTIVE ACTION
Low Inlet Pressure	Low supply pressure	Increase inlet pressure
	Cartridge filters plugged	Change filters
	Solenoid valve malfunction	Replace solenoid valve and/or coil
	Leaks	Fix any visible leaks
Low Permeate Flow	Low inlet flow	Adjust concentrate valve
	Cold feedwater	See temperature correction sheet
	Low operating pressure	See low inlet pressure
	Defective membrane brine seal	Inspect and/or replace brine seal
	Fouled or scaled membrane	Clean membranes
High Permeate Flow	Damaged product tube o-rings	Inspect and/or replace
	Damaged or oxidized membrane	Replace membrane
	Exceeding maximum feedwater temperature	See temperature correction sheet
Poor Permeate Quality	Low operating pressure	See low inlet pressure
	Damage product tube o-rings	Inspect and/or replace
	Damaged or oxidized membrane	Replace membrane
Membrane Fouling	Metal oxide fouling	Improve pretreatment to remove metals. Clean with acid cleaners
	Colloidal fouling	Optimize pretreatment for colloid removal. Clean with high pH anionic cleaners
	Scaling (CaSO ₄ , CaSO ₃ , BaSO ₄ , SiO ₂)	Increase acid addition and antiscalant dosage for CaVO ₃ and CaCO ₄ . Reduce recovery. Clean with acid cleaners
	Biological fouling	Shock dosage of sodium bi-sulfate. Continuous feed of sodium bi-sulfate at reduced pH. Chlorination and de-chlorination. Replace cartridge filters
	Organic fouling	Activated carbon or another pretreatment. Clean with high pH cleaner
	Abrasion of membrane by crystalline material	Improve pretreatment. Check all filters for media leakage

ABNORMAL PERMEATE FLOW

Permeate flow should be within 20% of the rated production, after correcting the feedwater temperatures above or below 77°F. Check the permeate flow meter to determine the permeate flow rate.

TO DETERMINE THE TEMPERATURE CORRECTION FACTOR, LOCATE THE TEMPERATURE CORRECTION TABLE IN THIS USER MANUAL AND FOLLOW THE DIRECTIONS.

OPERATING LOG

- Company Name _____

- Day of Start Up _____

- Location _____

- Date of Last Cleaning _____

- Week Of _____

- System Serial No. _____

Date					
Time					
Hour of Operation					
Filter Inlet Pressure (PSI)					
Filter Outlet Pressure (PSI)					
Concentrate Pressure (PSI)					
Pump Discharge Pressure (PSI)					
Feed Flow (GPM)					
Permeate Flow (GPM)					
Concentrate Flow (GPM)					
Recycle Flow (GPM)					
Recovery %					
Feed Temperature					
Feed TDS (PPM)					
Permeate TDS (PPM)					
Rejection %					
Feed pH					
Permeate pH					
Scale Inhibitor Feed (PPM)					
Iron (mg/L)					
Free Chlorine (mg/L)					
Hardness (GPG CaCO ₃)					

TEMPERATURE CORRECTION FACTORS FOR MEMBRANE

Find the temperature correction factor (TCF) from the table below. Divide the rated permeate flow at 77°F by the temperature correction factor. The result is the permeate flow at the desired temperature. (See example on the next page.)

Temperature °F (°C)	Temperature Correction Factor	Temperature °F (°C)	Temperature Correction Factor	Temperature °F (°C)	Temperature Correction Factor	Temperature °F (°C)	Temperature Correction Factor	Temperature °F (°C)	Temperature Correction Factor
50.0 (10.0)	1.711	57.2 (14.0)	1.475	64.4 (18.0)	1.276	71.6 (22.0)	1.109	78.8 (26.0)	0.971
50.2 (10.1)	1.705	57.4 (14.1)	1.469	64.6 (18.1)	1.272	71.8 (22.1)	1.105	79.0 (26.1)	0.968
50.4 (10.2)	1.698	57.6 (14.2)	1.464	64.8 (18.2)	1.267	72.0 (22.2)	1.101	79.2 (26.2)	0.965
50.5 (10.3)	1.692	57.7 (14.3)	1.459	64.9 (18.3)	1.262	72.1 (22.3)	1.097	79.3 (26.3)	0.962
50.7 (10.4)	1.686	57.9 (14.4)	1.453	65.1 (18.4)	1.258	72.3 (22.4)	1.093	79.5 (26.4)	0.959
50.9 (10.5)	1.679	58.1 (14.5)	1.448	65.3 (18.5)	1.254	72.5 (22.5)	1.090	79.7 (26.5)	0.957
51.1 (10.6)	1.673	58.3 (14.6)	1.443	65.5 (18.6)	1.249	72.7 (22.6)	1.086	79.9 (26.6)	0.954
51.3 (10.7)	1.667	58.5 (14.7)	1.437	65.7 (18.7)	1.245	72.9 (22.7)	1.082	80.1 (26.7)	0.951
51.4 (10.8)	1.660	58.6 (14.8)	1.432	65.8 (18.8)	1.240	73.0 (22.8)	1.078	80.2 (26.8)	0.948
51.6 (10.9)	1.654	58.8 (14.9)	1.427	66.0 (18.9)	1.236	73.2 (22.9)	1.075	80.4 (26.9)	0.945
51.8 (11.0)	1.648	59.0 (15.0)	1.422	66.2 (19.0)	1.232	73.4 (23.0)	1.071	80.6 (27.0)	0.943
52.0 (11.1)	1.642	59.2 (15.1)	1.417	66.4 (19.1)	1.227	73.6 (23.1)	1.067	80.8 (27.1)	0.940
52.2 (11.2)	1.636	59.4 (15.2)	1.411	66.6 (19.2)	1.223	73.8 (23.2)	1.064	81.0 (27.2)	0.937
52.3 (11.3)	1.630	59.5 (15.3)	1.406	66.7 (19.3)	1.219	73.9 (23.3)	1.060	81.1 (27.3)	0.934
52.5 (11.4)	1.624	59.7 (15.4)	1.401	66.9 (19.4)	1.214	74.1 (23.4)	1.056	81.3 (27.4)	0.932
52.7 (11.5)	1.618	59.9 (15.5)	1.396	67.1 (19.5)	1.210	74.3 (23.5)	1.053	81.5 (27.5)	0.929
52.9 (11.6)	1.611	60.1 (15.6)	1.391	67.3 (19.6)	1.206	74.5 (23.6)	1.049	81.7 (27.6)	0.926
53.1 (11.7)	1.605	60.3 (15.7)	1.386	67.5 (19.7)	1.201	74.7 (23.7)	1.045	81.9 (27.7)	0.924
53.2 (11.8)	1.600	60.4 (15.8)	1.381	67.6 (19.8)	1.197	74.8 (23.8)	1.042	82.0 (27.8)	0.921
53.4 (11.9)	1.594	60.6 (15.9)	1.376	67.8 (19.9)	1.193	75.0 (23.9)	1.038	82.2 (27.9)	0.918
53.6 (12.0)	1.588	60.8 (16.0)	1.371	68.0 (20.0)	1.189	75.2 (24.0)	1.035	82.4 (28.0)	0.915
53.8 (12.1)	1.582	61.0 (16.1)	1.366	68.2 (20.1)	1.185	75.4 (24.1)	1.031	82.6 (28.1)	0.913
54.0 (12.2)	1.576	61.2 (16.2)	1.361	68.4 (20.2)	1.180	75.6 (24.2)	1.028	82.8 (28.2)	0.910
54.1 (12.3)	1.570	61.3 (16.3)	1.356	68.5 (20.3)	1.176	75.7 (24.3)	1.024	82.9 (28.3)	0.908
54.3 (12.4)	1.564	61.5 (16.4)	1.351	68.7 (20.4)	1.172	75.9 (24.4)	1.021	83.1 (28.4)	0.905
54.5 (12.5)	1.558	61.7 (16.5)	1.347	68.9 (20.5)	1.168	76.1 (24.5)	1.017	83.3 (28.5)	0.902
54.7 (12.6)	1.553	61.9 (16.6)	1.342	69.1 (20.6)	1.164	76.3 (24.6)	1.014	83.5 (28.6)	0.900
54.9 (12.7)	1.547	62.1 (16.7)	1.337	69.3 (20.7)	1.160	76.5 (24.7)	1.010	83.7 (28.7)	0.897
55.0 (12.8)	1.541	62.2 (16.8)	1.332	69.4 (20.8)	1.156	76.6 (24.8)	1.007	83.8 (28.8)	0.894
55.2 (12.9)	1.536	62.4 (16.9)	1.327	69.6 (20.9)	1.152	76.8 (24.9)	1.003	84.0 (28.9)	0.892
55.4 (13.0)	1.530	62.6 (17.0)	1.323	69.8 (21.0)	1.148	77.0 (25.0)	1.000	84.2 (29.0)	0.889
55.6 (13.1)	1.524	62.8 (17.1)	1.318	70.0 (21.1)	1.144	77.2 (25.1)	0.997	84.4 (29.1)	0.887
55.8 (13.2)	1.519	63.0 (17.2)	1.313	70.2 (21.2)	1.140	77.4 (25.2)	0.994	84.6 (29.2)	0.884
55.9 (13.3)	1.513	63.1 (17.3)	1.308	70.3 (21.3)	1.136	77.5 (25.3)	0.991	84.7 (29.3)	0.882
56.1 (13.4)	1.508	63.3 (17.4)	1.304	70.5 (21.4)	1.132	77.7 (25.4)	0.988	84.9 (29.4)	0.879
56.3 (13.5)	1.502	63.5 (17.5)	1.299	70.7 (21.5)	1.128	77.9 (25.5)	0.985	85.1 (29.5)	0.877
56.5 (13.6)	1.496	63.7 (17.6)	1.294	70.9 (21.6)	1.124	78.1 (25.6)	0.982	85.3 (29.6)	0.874
56.7 (13.7)	1.491	63.9 (17.7)	1.290	71.1 (21.7)	1.120	78.3 (25.7)	0.979	85.5 (29.7)	0.871
56.8 (13.8)	1.486	64.0 (17.8)	1.285	71.2 (21.8)	1.116	78.4 (25.8)	0.977	85.6 (29.8)	0.869
57.0 (13.9)	1.480	64.2 (17.9)	1.281	71.4 (21.9)	1.112	78.6 (25.9)	0.974	85.8 (29.9)	0.866

*F = (°C x 9/5) + 32

Corrected Flow Rate = (Measured Flow Rate) * (TCF @ Feed Water Temp.)

If a system is rated to produce 5 gpm of permeate water at 77°F, the same system will produce more water at a higher temperature. It will also produce less water at a lower temperature. Use the temperature correction table to obtain the correct flow.

Example:

5 gpm at 59°F ($5 \div 1.42 = 3.52$ gpm)

5 gpm at 77°F ($5 \div 1 = 5$ gpm)

5 gpm at 84°F ($5 \div 0.89 = 5.62$ gpm)

SERVICE ASSISTANCE

If service assistance is required:

- Contact your local dealer or distributor
- Prior to making the call, have the following information available:
 - System installation date
 - Serial number
 - Daily log sheets
 - Current operating parameters (e.g., flow, operating pressures, pH, etc.)
 - Detailed description of the problem

SYSTEM DRAWINGS

MODELS	ECO – 2000	ECO – 4000	ECO – 6000	ECO – 8000
Dimensions				
"A" DIM	55.43	55.43	55.43	55.43
"B" DIM	48.19	48.19	48.19	48.19
"C" DIM	21.75	21.75	21.75	21.75
"D" DIM	23.75	23.75	23.75	23.75
"E" DIM	24.62	24.62	24.62	24.62
"F" DIM	25.92	30.08	30.08	30.08

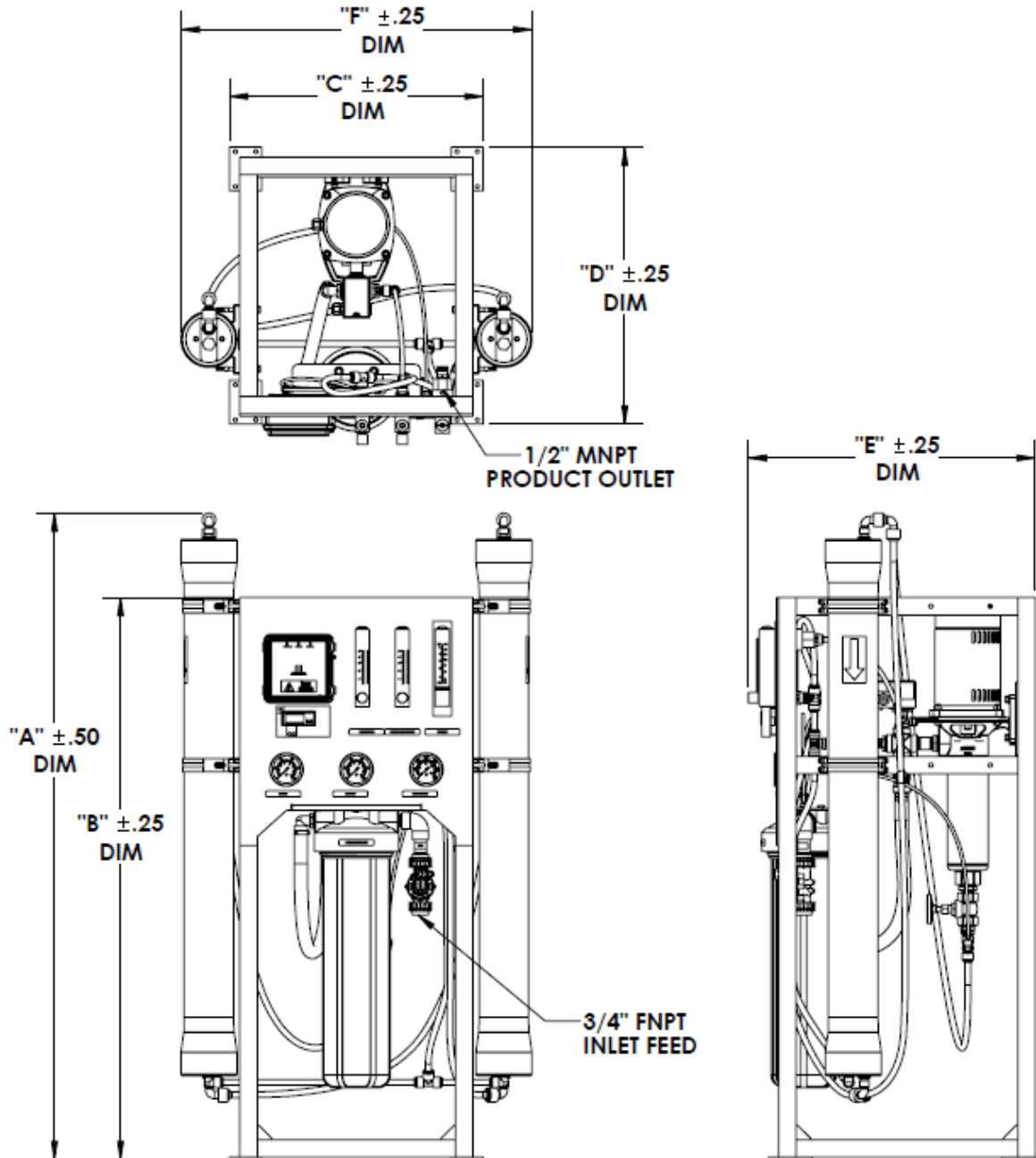

ECO – 4000 FLOW DIAGRAM

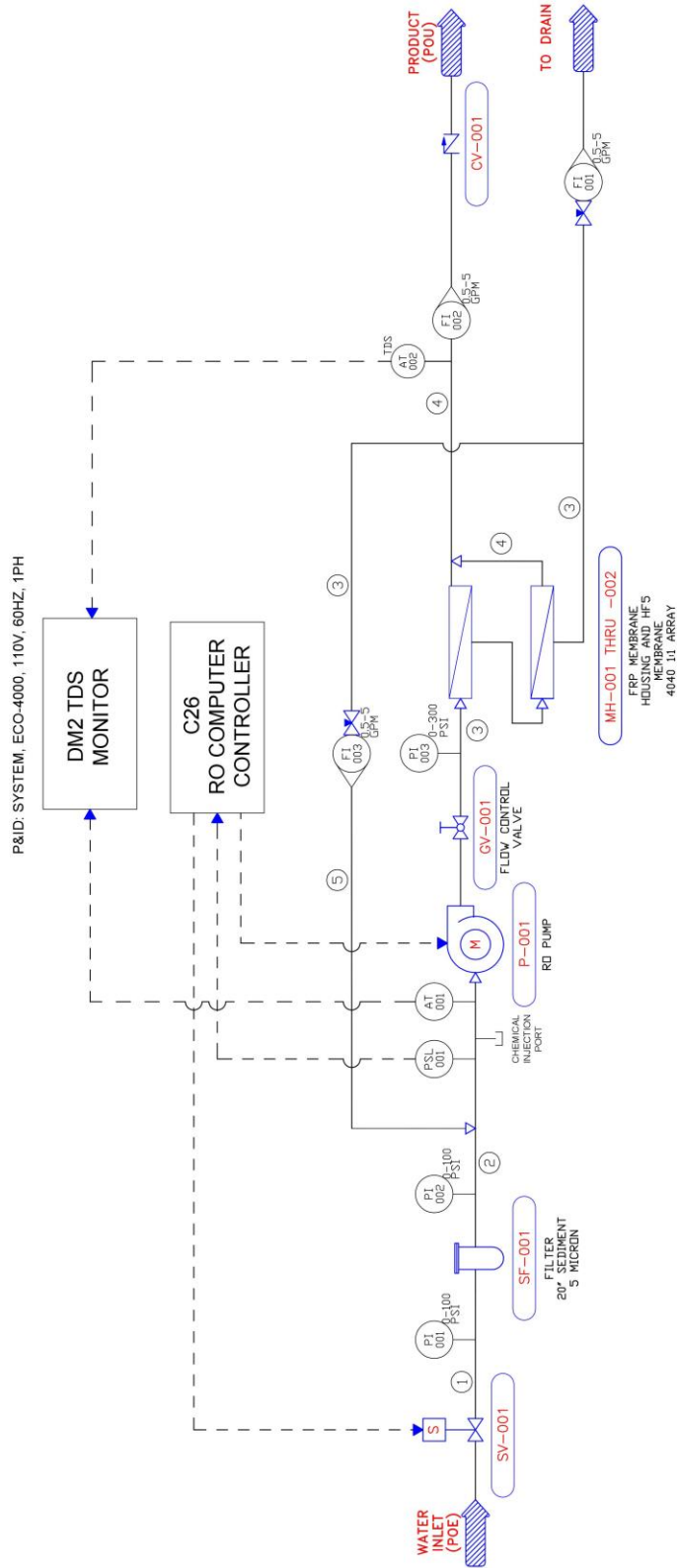

VALVE SYMBOLS	MISCELLANEOUS SYMBOLS	LINE SYMBOLS	PIPING SIZE																		
SOLENOID VALVE BALL VALVE GLOBE VALVE NEEDLE VALVE AUTO FLUSH VALVE PURGE VALVE CHECK VALVE	PUMP FILTER MEMBRANE FLOW RESTRICTOR	PRESSURE INDICATOR PRESSURE SWITCH LOW TDS FLOW INDICATOR (ROTAMETER) FLOW INDICATOR (WITH NEEDLE VALVE)	<table border="1"> <thead> <tr> <th>STREAM</th> <th>SIZE</th> <th>MATERIAL</th> </tr> </thead> <tbody> <tr> <td>1</td> <td>3/4"</td> <td>PVC (SCH. 80)</td> </tr> <tr> <td>2</td> <td>3/4"</td> <td>PVC HOSE / SS</td> </tr> <tr> <td>3</td> <td>1/2"</td> <td>HP POLY TUBE</td> </tr> <tr> <td>4</td> <td>1/2"</td> <td>LP POLY TUBE</td> </tr> <tr> <td>5</td> <td>3/8"</td> <td>POLY TUBE</td> </tr> </tbody> </table>	STREAM	SIZE	MATERIAL	1	3/4"	PVC (SCH. 80)	2	3/4"	PVC HOSE / SS	3	1/2"	HP POLY TUBE	4	1/2"	LP POLY TUBE	5	3/8"	POLY TUBE
STREAM	SIZE	MATERIAL																			
1	3/4"	PVC (SCH. 80)																			
2	3/4"	PVC HOSE / SS																			
3	1/2"	HP POLY TUBE																			
4	1/2"	LP POLY TUBE																			
5	3/8"	POLY TUBE																			
PRESSURE INDICATOR PRESSURE SWITCH LOW TDS FLOW INDICATOR (ROTAMETER) FLOW INDICATOR (WITH NEEDLE VALVE)		<table border="1"> <thead> <tr> <th>LINE SYMBOLS</th> </tr> </thead> <tbody> <tr> <td> PIPING PROCESS CONNECTION ELECTRICAL SIGNAL </td> </tr> </tbody> </table>	LINE SYMBOLS	PIPING PROCESS CONNECTION ELECTRICAL SIGNAL																	
LINE SYMBOLS																					
PIPING PROCESS CONNECTION ELECTRICAL SIGNAL																					

ECO – 6000 FLOW DIAGRAM

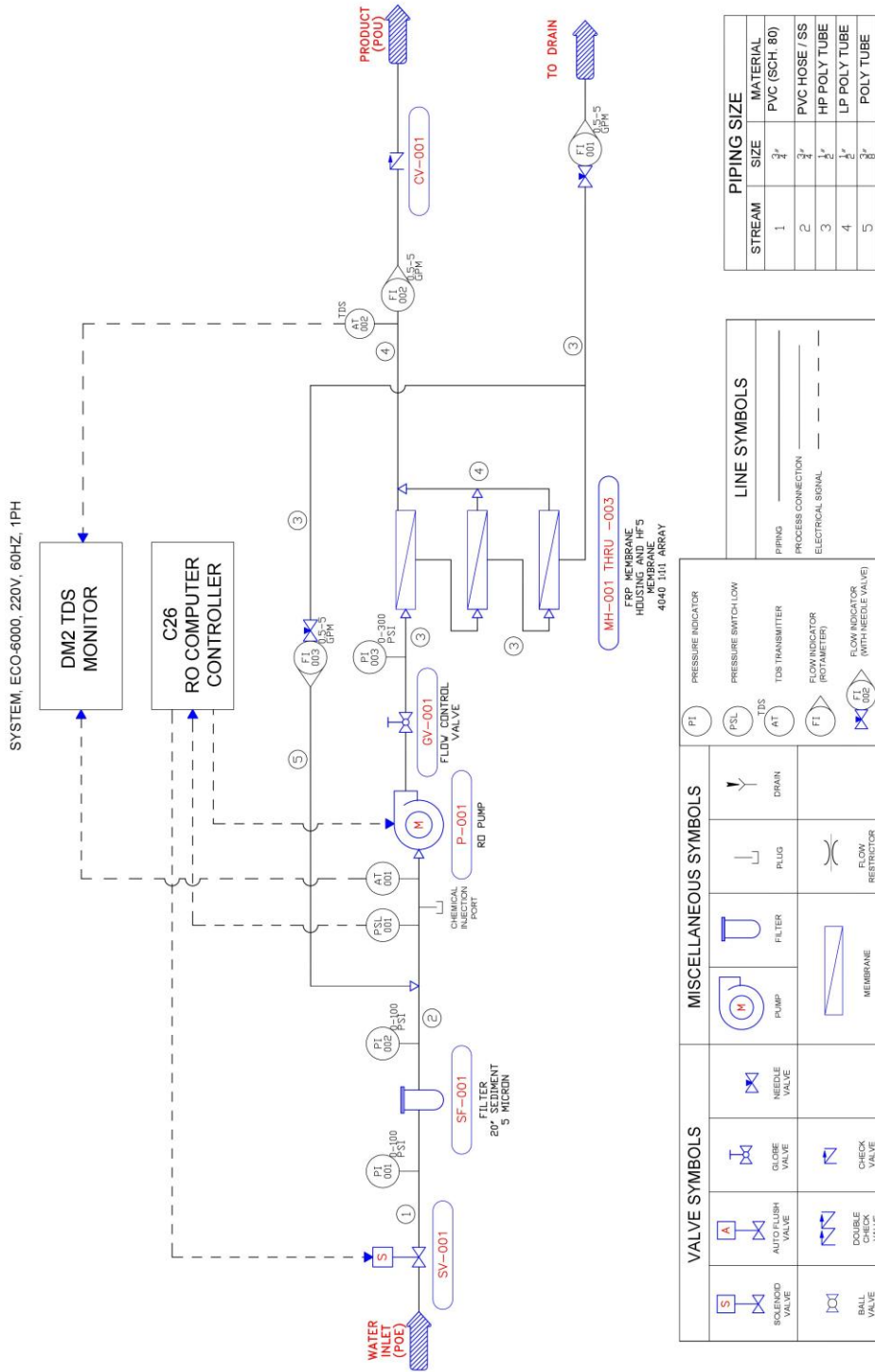

ECO – SERIES

ELECTRICAL SCHEMATIC

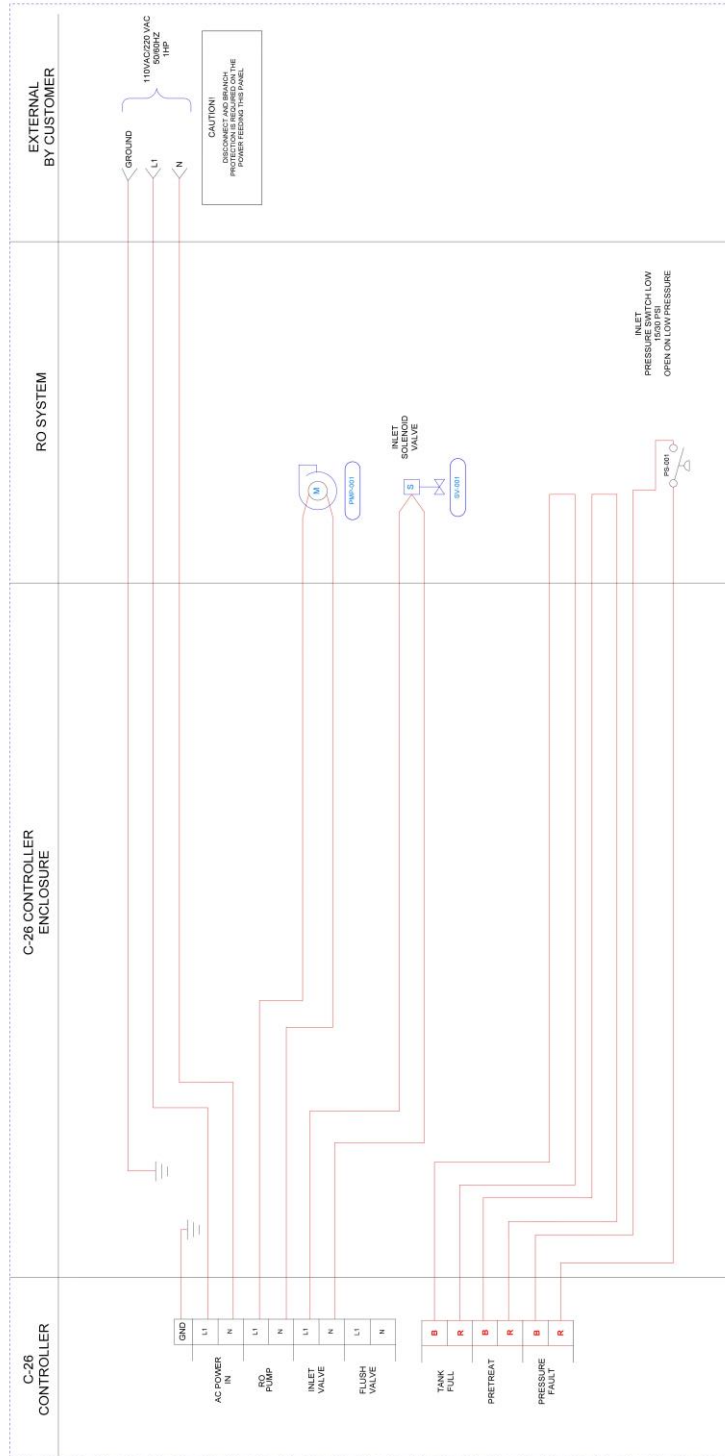

ELECTRICAL SYMBOLS	ABBREVIATIONS	WIRE DESCRIPTION	WIRE GAUGE
	COIL	MAIN POWER WIRES	12-3 AWG
	MOTOR	PUMP WIRES	12-3 AWG
	OVERLOAD	SOLENOID WIRES	18 AWG
	N.C. CONTACT	TANK FILL	22-2 AWG
	N.O. CONTACT	PRETREAT	22-2 AWG
	FUSE	LPS	22-2 AWG
	PRESSURE SWITCH		
	TERMINAL BLOCK		
	GROUND		
	FILTER		
	LED LIGHT		
	MISCELLANEOUS SYMBOLS		
	PUMP		
	SOLENOID VALVE		
	TDS CELL		
	CHEMICAL PUMP		

SYSTEM WARRANTY

One-Year Limited Warranty

Warranty Terms

Subject to the terms and conditions set forth hereinafter, manufacturer (hereafter “Manufacturer”) warrants to the original purchaser (hereafter the “Customer”) that the systems and products manufactured by the Manufacturer are free from defects in material and in workmanship for twelve (12) months from the Warranty Commencement Date (as defined below) only when used strictly in accordance with the applicable operating instructions and within the range of the operating conditions specified by the Manufacturer for each such product.

In order to maintain the Manufacturer’s Warranty, an operating log must be maintained and copies will need to be sent to your local dealer or distributor for review. This Warranty does not extend to systems, equipment, or components manufactured by others, nor to systems, equipment, or components manufactured by others and distributed by the Manufacturer. This Warranty does not extend to equipment or components manufactured by others which have been incorporated into a product by the Manufacturer but, if allowable, the Manufacturer hereby assigns, without Warranty, to the Customer its interest, if any, under any Warranty made by the Manufacturer of such equipment or component. This Warranty does not cover disposable items such as fuses, o-rings, regeneration materials/chemicals, or other such disposable items, which must be replaced periodically under the normal and foreseeable operating conditions of the goods warranted hereby.

Warranty Commencement Date

The Warranty Commencement Date for each product by the Manufacturer shall be the later of the date of: (1) receipt by the Customer, or (2) the date of installation at the Customer’s premises provided that such installation must occur within three (3) months of shipment from the Manufacturer’s manufacturing facility. In no event shall the Warranty Commencement Date exceed three (3) months from the shipment from Manufacturer’s facility. The Customer shall provide proof of purchase in order to exercise rights granted under this Warranty. If requested by the Manufacturer, the Customer must also provide proof of the installation date. Proof of installation shall be returned by Customer to the Manufacturer within thirty (30) days after installation by virtue of supplying a Warranty Validation Card supplied with each Manufacturer product fully completed and signed in ink by the Customer and the authorized installer of the product.

Warranty Service

MANUFACTURER’S OBLIGATION UNDER THIS WARRANTY IS LIMITED TO THE REPAIR OR REPLACEMENT (AT MANUFACTURER’S SOLE DISCRETION) OF ANY PRODUCT, OR COMPONENT THEREOF, PROVED TO BE DEFECTIVE IN MATERIAL OR WORKMANSHIP WITHIN THE COVERED WARRANTY PERIOD.

The Customer, at the Customer’s risk and expense, shall be responsible for returning such product or component, only after obtaining a Return Goods Authorization (RGA) number from the Manufacturer, arranging for freight prepaid, and in conformance with any special packaging and shipping instructions set forth on the operation documentation or RGA instructions, or as otherwise reasonably required, to Manufacturer’s address, together with (1) RGA number issued by the Manufacturer at Customer’s request; (2) proof of purchase and, if necessary, proof of installation date; (3) a Return Goods Authorization Form; (4) a description of the suspected defects; (5) the serial number of the Manufacturer product alleged to be defective; and (6) a description of the type of water and pretreatment equipment which has been utilized in connection with the product, if any; (7) an operating log, which can be found in the product manual. Manufacturer shall, in Manufacturer’s reasonable discretion, be the sole judge of whether a returned product or component is defective in material or workmanship.

Required or replaced products or components shall be returned surface freight. In genuine emergency situations, Manufacturer will at Manufacturer's sole discretion) forward replacement parts to Customer without waiting for authorized return of the questionable part(s). In such cases, Customer will issue a purchase order or other payment guarantee prior to shipment. If the returned part is found to have been misused or abused, or the defective part is not received by Manufacturer within thirty (30) days; the Customer will be invoiced for the replacement part(s) provided. This Warranty does not cover or include labor and/or travel to the Customer's premise or location or any other location. Charges of \$1000 per day plus associated travel expenses will be incurred by the Customer in providing the Warranty Service at any location other than Manufacturer's main headquarters; that is if the Manufacturer deems that the product is not covered by said Warranty. The Manufacturer reserves the right to precondition such travel to Customer's premises upon prepayment of Manufacturer's anticipated costs of attending such premises.

Voidability of Warranty

This Warranty shall be void and unenforceable as to any Manufacturer product which has been damaged by accident, mishandling, abuse or has been repaired, modified, altered, disassembled or otherwise tampered with by anyone other than Manufacturer or an authorized Manufacturer service representative; or, if any replacement parts are not authorized by Manufacturer have been used, or, the product has not been installed, operated and maintained in strict accordance and adherence with the operating documentation and manuals for such product. Any expressed Warranty, or similar representation of performance set forth in the operation documentation for media or resin incorporated into a product by the Manufacturer shall be void and unenforceable unless the feed water requirements set forth in the operating documentation for such product are unequivocally and strictly adhered to.

Limitations and Exclusions

THIS WARRANTY AND REMEDIES DESCRIBED HEREIN AND HEREINABOVE ARE EXCLUSIVE AND IN LIEU OF ANY AND ALL OTHER WARRANTY OR REMEDIES, EXPRESSED OR IMPLIED, INCLUDING WITHOUT LIMITATION, ANY IMPLIED WARRANTY OF MERCHANTABILITY OR FITNESS FOR A PARTICULAR PURPOSE. IN NO EVENT SHALL THE MANUFACTURER BE LIABLE FOR ANY CONSEQUENTIAL, INCIDENTAL OR OTHER SIMILAR TYPES OF DAMAGES, FOR DAMAGES FOR THE LOSS OF PRODUCTION OR PROFITS, OR INJURY TO PERSON OR PROPERTY. NO PERSON HAS ANY AUTHORITY TO BIND THE MANUFACTURER TO OTHER THAN WHAT IS SET FORTH ABOVE.

THIS WARRANTY GIVES THE CUSTOMER SPECIFIC LEGAL RIGHTS AND THE CUSTOMER MAY ALSO HAVE OTHER RIGHTS WHICH VARY FROM JURISDICTION TO JURISDICTION. THE PARTIES RECOGNIZE AND AGREE, THAT IN ALL RESPECTS THE LAWS OF THE STATE OF CALIFORNIA SHALL APPLY TO AND SHALL GOVERN ANY INTERPRETATION OR LEGAL SIGNIFICANCE OF THIS DOCUMENT.

NO WARRANTY OR OTHER LIABILITY OF THE MANUFACTURER TO CUSTOMER UNDER THIS AGREEMENT OR OTHERWISE WILL IN ANY EVENT EXCEED THE COST OF REPLACEMENT OF THE APPLICABLE MANUFACTURER PRODUCT, PART, OR ACCESSORY THAT IS SUBJECT TO ANY BREACH OF MANUFACTURER'S WARRANTY. MANUFACTURER WILL NOT BE LIABLE FOR ANY DAMAGE TO ANY PROPERTY OF CUSTOMER OR TO CUSTOMER'S CUSTOMERS FOR ANY CONSEQUENTIAL, INCIDENTAL, OR ECONOMIC LOSS OR COMMERCIAL DAMAGE WHATSOEVER. REMEDIES HEREIN PROVIDED ARE EXPRESSLY MADE THE SOLE AND EXCLUSIVE REMEDIES FOR BREACH OF ANY WARRANTY OR OTHER OBLIGATION HEREUNDER EXPRESS OR IMPLIED OR FROM THE OPERATION OF LAW.