

OWNER'S MANUAL

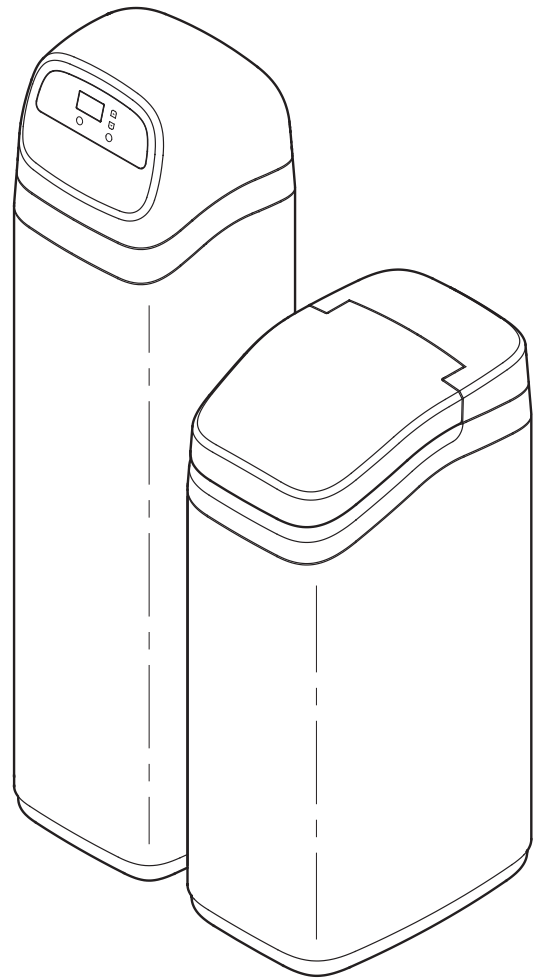
How to install, operate and maintain your EcoWater Systems Solid State Timer Water System

ECOWATER
S Y S T E M S®



Your Water. Perfected.

Model
ESS1152XR32



System tested and certified by NSF International
against NSF/ANSI Standard 44
for hardness reduction,
and certified to NSF/ANSI/CAN Standard 372.

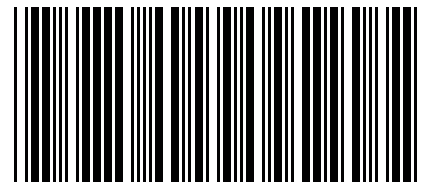


System tested and certified by the
Water Quality Association against CSA B483.1.



Designed, Engineered &
Assembled in the U.S.A.

EcoWater Systems LLC
P.O. Box 64420, St. Paul, MN 55164-0420
www.ecowater.com



7368205 (Rev. F 1/25/22)

TABLE OF CONTENTS

	<u>Page</u>
Warranty	3
Specifications & Performance Claims	4
Dimensions	5
Before Starting Installation	6
Media Loading	7
Typical Installation Illustrations	8
Installation Instructions	9-12
Sanitizing Procedure	12
Programming the Electronic Controller	13-19
Programming the Electronic Controller (Softeners)	13-14
Controller Features / Options (Softeners)	15
Programming the Electronic Controller (Filters)	16
Controller Features / Options (Filters)	16-17
Features (All Models)	17-19
Wiring Schematic	18
Routine Maintenance	20-21
Troubleshooting	22-23
Repair Parts	24-27

INSPECT SHIPMENT

The parts required to assemble and install the water softener are included with the unit. Thoroughly check the water softener for possible shipping damage and parts loss. Also inspect and note any damage to the shipping carton.

Remove and discard (or recycle) all packing materials. To avoid loss of small parts, we suggest you keep the small parts in the parts bag until you are ready to use them.

SAFETY GUIDES

Follow the installation instructions carefully. Failure to install the water softener properly voids the warranty.

Before you begin installation, read this entire manual. Then obtain all the materials and tools you will need to make the installation.

Check local plumbing and electrical codes. The installation must conform to them.

Use only lead-free solder and flux for all sweat-solder connections as required by state and federal codes.

Use care when handling the water softener. Do not turn upside down, drop, or set on sharp protrusions.

Do not locate the water softener where freezing temperatures occur. **Do not attempt to treat water over 120°F.** Freezing, or hot water damage voids the warranty.

The water softener requires a minimum water flow of 3 gallons per minute at the inlet.

Recommended **maximum allowable inlet water pressure is 125 psi.** If daytime pressure is over 80 psi, nighttime pressure may exceed the maximum. Use a pressure reducing valve if necessary. Be sure the addition of a pressure reducing valve will not reduce the flow to less than the 3 gallons per minute.

The water softener works on **24V DC** electrical power, supplied by a direct plug-in power supply (included). Be sure to use the included power supply, and plug it into a nominal **120V, 60 Hz** household outlet that is in a **dry location only**, grounded and properly protected by an overcurrent device such as circuit breaker or fuse.

This system is not intended to be used for treating water that is microbiologically unsafe or of unknown quality without adequate disinfection before or after the system.



European Directive 2002/96/EC requires all electrical and electronic equipment to be disposed of according to Waste Electrical and Electronic Equipment (WEEE) requirements. This directive or similar laws are in place nationally and can vary from region to region. Please refer to your state and local laws for proper disposal of this equipment.

LIMITED WARRANTY

EcoWater Systems LLC Advantage Warranty ESS1152XR32 Water Conditioning System

Congratulations! You have just purchased the highest quality water conditioning product on the market.

To whom is this warranty extended?

EcoWater Systems LLC warrants its products to the original owner and guarantees that the products will be free from defects in materials and workmanship from the original date of installation.

How does my warranty work?

If, during the respective warranty period, a part proves, after inspection by EcoWater, to be defective, EcoWater will, at its sole option repair or replace that part at no charge, other than normal shipping, installation or service charges.

What is covered by the warranty?

EcoWater Systems LLC guarantees that, for the LIFETIME of the original owner, the MINERAL TANK will not rust, corrode, leak, burst, or in any other manner fail to perform its proper functions and that, for a period of TEN (10) YEARS after installation, the SALT TANK will be free of defects in materials and workmanship and will perform its proper function and that, for a period of THREE (3) YEARS after installation, the VALVE BODY, ELECTRONIC FACEPLATE and ALL OTHER PARTS will be free of defects in materials and workmanship and will perform their normal functions.

How do I obtain warranty service?

Should you need service, your local, independent EcoWater Dealer is only a phone call away.

PHONE: _____

To obtain warranty service, notice must be given, within thirty (30) days of the discovery of the defect, to your local EcoWater Systems dealer.

If I need a part replaced after the factory warranty expires, is the replacement part warranted?

Yes, EcoWater Systems LLC warrants FACTORY REPAIRS as well as all REPLACEMENT PARTS for a period of 90 DAYS. This warranty does not include normal shipping, installation or service charges.

Are any additional warranties available?

We are pleased to say, YES! EcoWater Systems LLC sells an EXTENDED, PARTS ONLY WARRANTY for the ELECTRONICS portion of your product. This warranty is called the "Perfect Ten" and extends the three year warranty on the electronic FACEPLATE, WIRING HARNESS, DRIVE MOTOR, POWER SUPPLY, POWER CORD, SENSOR HOUSING, and MICRO SWITCHES to a total of TEN YEARS from the date of original installation. Your local dealer will provide details regarding this warranty or will refer you to the factory for additional information. Should your local dealer not offer this warranty, you may contact the factory for additional information.* This guarantee may be subject to normal shipping and installation or service charges.

General Provisions

The above warranties are effective provided the water conditioner is operated at water pressures not exceeding 125 psi, and at water temperatures not exceeding 120°F; provided further that the water conditioner is not subject to abuse, misuse, alteration, neglect, freezing, accident or negligence; and provided further that the water conditioner is not damaged as the result of any unusual force of nature such as, but not limited to, flood, hurricane, tornado or earthquake. EcoWater Systems LLC is excused if failure to perform its warranty obligations is the result of strikes, government regulation, materials shortages, or other circumstances beyond its control.

*THERE ARE NO WARRANTIES ON THE WATER CONDITIONER BEYOND THOSE SPECIFICALLY DESCRIBED ABOVE. ALL IMPLIED WARRANTIES, INCLUDING ANY IMPLIED WARRANTY OF MERCHANTABILITY OR OF FITNESS FOR A PARTICULAR PURPOSE, ARE DISCLAIMED TO THE EXTENT THEY MIGHT EXTEND BEYOND THE ABOVE PERIODS. THE SOLE OBLIGATION OF ECOWATER SYSTEMS LLC UNDER THESE WARRANTIES IS TO REPLACE OR REPAIR THE COMPONENT OR PART WHICH PROVES TO BE DEFECTIVE WITHIN THE SPECIFIED TIME PERIOD, AND ECOWATER IS NOT LIABLE FOR CONSEQUENTIAL OR INCIDENTAL DAMAGES. NO ECOWATER DEALER, AGENT, REPRESENTATIVE, OR OTHER PERSON IS AUTHORIZED TO EXTEND OR EXPAND THE WARRANTIES EXPRESSLY DESCRIBED ABOVE.

Some states do not allow limitations on how long an implied warranty lasts or exclusions or limitations of incidental or consequential damage, so the limitations and exclusions in this warranty may not apply to you. This warranty gives you specific legal rights, and you may have other rights which vary from state to state. This warranty applies to consumer-owned installations only.

This softener has been proven to deliver soft water for at least ten continuous minutes at the rated service flow rate.

SPECIFICATIONS	
Model	ESS1152XR32
Model Code	ST31
Rated Softening Capacity (grains @ lb. salt dose)	13,400 @ 2.9 28,600 @ 9.2 34,400 @ 15.6
Water Used During Regeneration @ Minimum Salt Dose	56.2 gal. / 1,000 grains
Amount of High Capacity Resin	51 lbs. (0.98 cu. ft.)
Resin Tank Nominal Size (dia. x height)	10 x 47 in.
Service Flow Rate	8.3 gpm
Pressure Drop at Rated Service Flow	14.9 psig
Intermittent Flow @ 15 psi ▲	8.3 gpm
Intermittent Flow @ 30 psi ▲	12.2 gpm
Water Supply Maximum Hardness	110 gpg
Water Supply Maximum Clear Water Iron ■	5 ppm
Min. - Max. Water Supply Pressure ◆	20 - 125 psi
Min. - Max. Water Supply Temperature	40 - 120 °F
Minimum Water Supply Flow Rate	3 gpm
Max Drain Flow Rate	2.2 gpm

- ▲ Intermittent flow rate does not represent the maximum service flow rate used for determining the unit's rated capacity and efficiency. Continuous operation at flow rates greater than the service flow rate may affect capacity and efficiency performance.
- Capacity to remove clear water iron is substantiated by independent laboratory test data. State of Wisconsin requires additional treatment if water supply contains greater than 5 ppm clear water iron.
- ◆ Canada working pressure limits: 1.4 - 7.0 kg/cm².

This system, when containing EcoWater Systems resin part number 0502272 in the amount listed above, conforms to NSF/ANSI 44 for the specific performance claims as verified and substantiated by test data.

Model	Nominal Resin Tank Size
ESS1152XR32	10" dia. x 47"

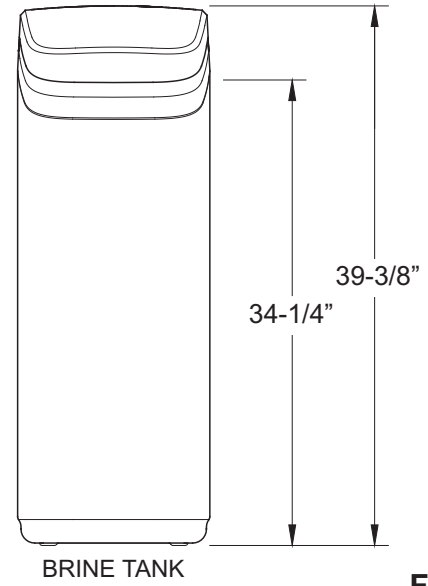
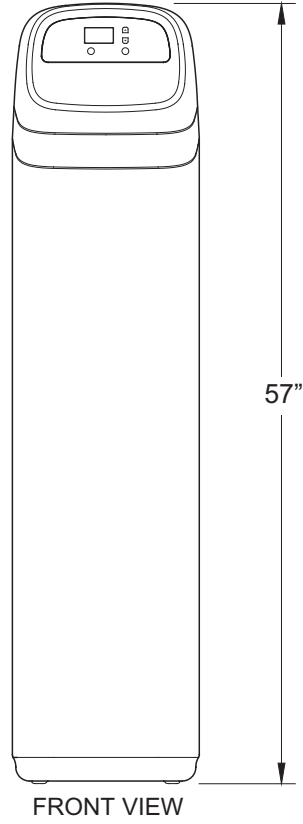
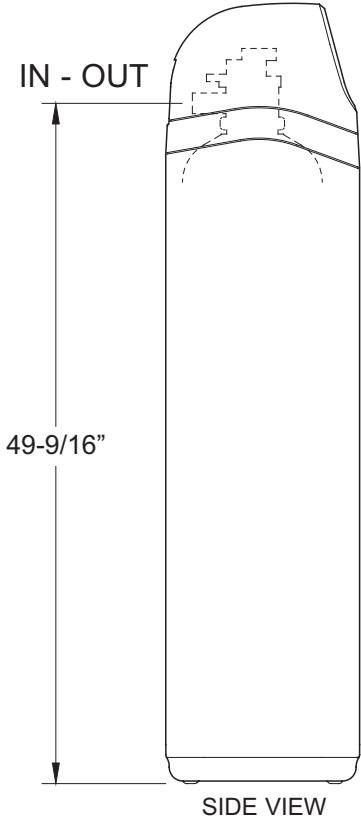
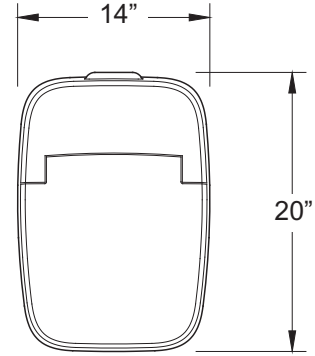
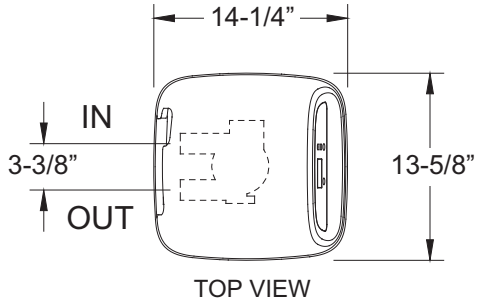


FIG. 1

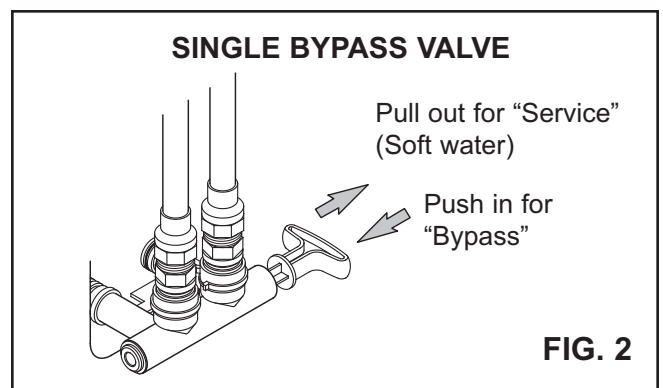
WHERE TO INSTALL THE SOFTENER

- To soften all water in the home, install the water softener close to the water supply inlet, upstream of all other plumbing connections, **except** outside water pipes. Outside faucets should remain on hard water to conserve salt and softening capacity.
- Place the softener near a floor drain, or other acceptable drain point (laundry tub, sump, standpipe, etc.) to carry away regeneration discharge water.
- Connect the softener to the main water supply pipe **UPSTREAM OF** the water heater. **DO NOT RUN HOT WATER THROUGH THE SOFTENER.** The temperature of water passing through the softener must be less than 120°F.
- Do not install the softener in a place where it could freeze. Damage caused by freezing is not covered by the warranty.
- Put the softener in a place water damage is least likely to occur if a leak develops. The manufacturer will not repair or pay for water damage.
- A 120V, 60 Hz electrical outlet, to plug the included power supply into, is needed near the softener. Be sure the electrical outlet and power supply are in an inside location, to protect from wet weather.
- If installing in an outside location, you must take the steps necessary to assure the softener, installation plumbing, wiring, etc., are as well protected from the elements, contamination, vandalism, etc., as when installed indoors.
- A drain is needed for recharge discharge water. A floor drain is preferred, close to the water softener. A laundry tub, standpipe, etc., are other options. Be sure to provide a 1-1/2" minimum air gap, to prevent possible sewer water backup.

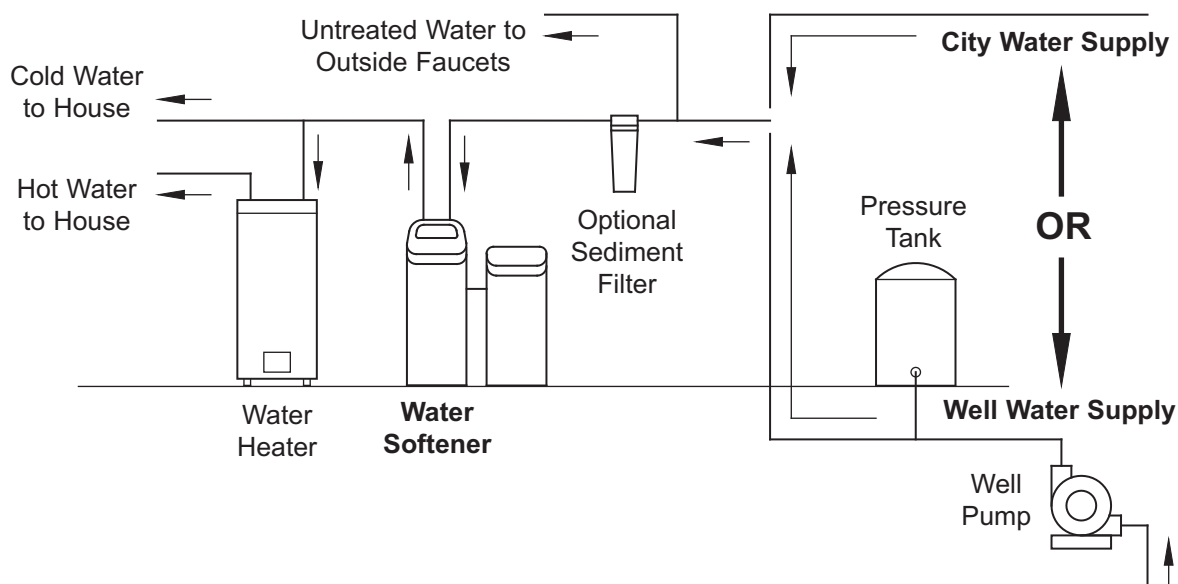
TOOLS, PIPE & FITTINGS, OTHER MATERIALS YOU WILL NEED

- **ALWAYS** install an EcoWater Systems bypass valve, or a 3-valve bypass system. Bypass valves let you turn off water to the softener for repairs if needed, but still have water available to the house pipes.
- Plastic inlet and outlet fittings are included with the softener, which allow water flow equivalent to 1 inch nominal pipe. To maintain maximum valve flow, 1" pipes to and from the softener fittings are recommended. Do not reduce the pipes to less than 3/4" size.
- Use copper, brass or PEX plastic pipe and fittings.
- Drain hose, 1/2" inside diameter minimum, is needed for the valve drain.
- If a rigid valve drain is needed, to comply with plumbing codes, you can buy the parts needed to connect a 1/2" minimum copper tubing drain.

NOTE: The Commonwealth of Massachusetts plumbing code 248-CMR shall be adhered to. A licensed plumber shall be used for this installation.



THE PROPER ORDER TO INSTALL WATER TREATMENT EQUIPMENT



MEDIA LOADING

Model ESS1152XR32, as manufactured, contains no media. Before plumbing the system, load media (See table on Page 13 for amounts):

1. Move the system into installation location and set it on a flat, level surface.
2. Take off the unit's top cover and unplug the wiring connections between the valve and the control board (PWA).
3. Remove retainer clips and clamp sections from the tank neck and carefully lift the valve off the tank.
4. Remove the top distributor from the tank neck, leaving the bottom distributor (including riser pipe) in place. Center the distributor in the tank.
5. With a pail or hose, fill the tank with about 12" of water. The water acts as a cushion to protect the bottom distributor while filling the tank with gravel and media.
6. Cover the top end of the distributor riser pipe with a clean rag, to keep gravel and media out (See Fig. 4).
7. Using a larger neck funnel, add the gravel (if used) and media in that order. Be sure the distributor remains centered. Use water sparingly to speed flow through the funnel (It may become necessary to siphon water from the bottom of distributor if tank becomes full of water).
8. Flush the tank opening with water to clean media particles from the top of the tank. Uncover the bottom distributor riser pipe.
9. Finish filling the tank with water, up to the top of the tank.

IMPORTANT: Be sure to fill with water. This will eliminate air space and prevent excessive air-head pressure when tank is pressurized.

10. Install the o-ring seals and top distributor exactly as shown in Figure 5. If the o-rings need lubrication, use a high quality silicone grease.
11. Lower the valve assembly onto the tank, centering over the riser tube. Push downward, against the o-ring, and install the clamp sections, securing with the retainer clips.
12. Reconnect the wiring between the valve and the control board (PWA).

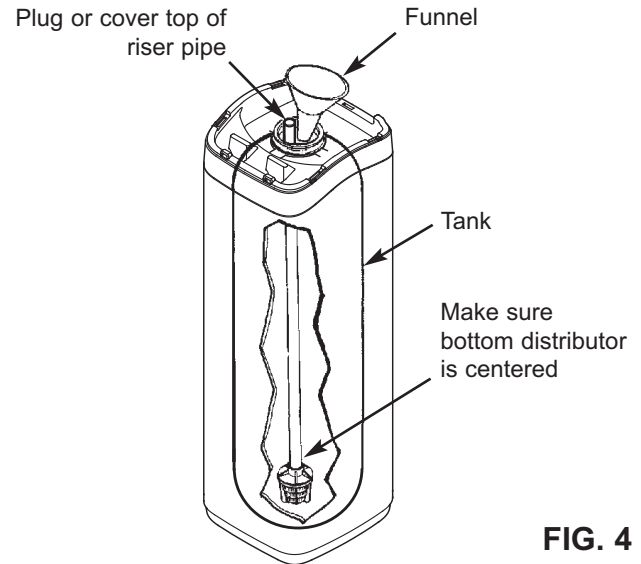


FIG. 4

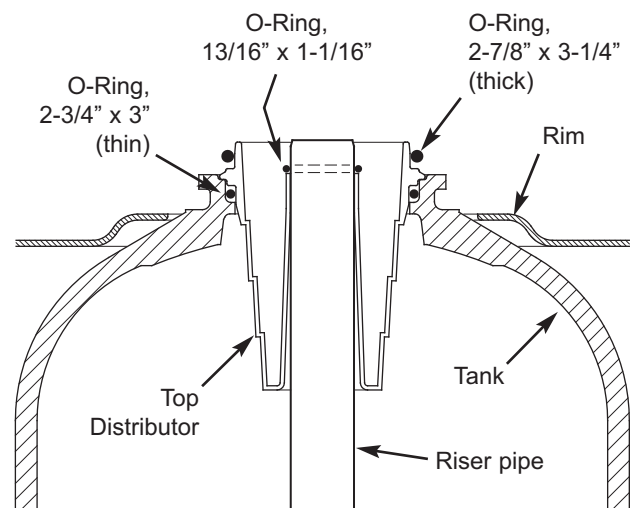
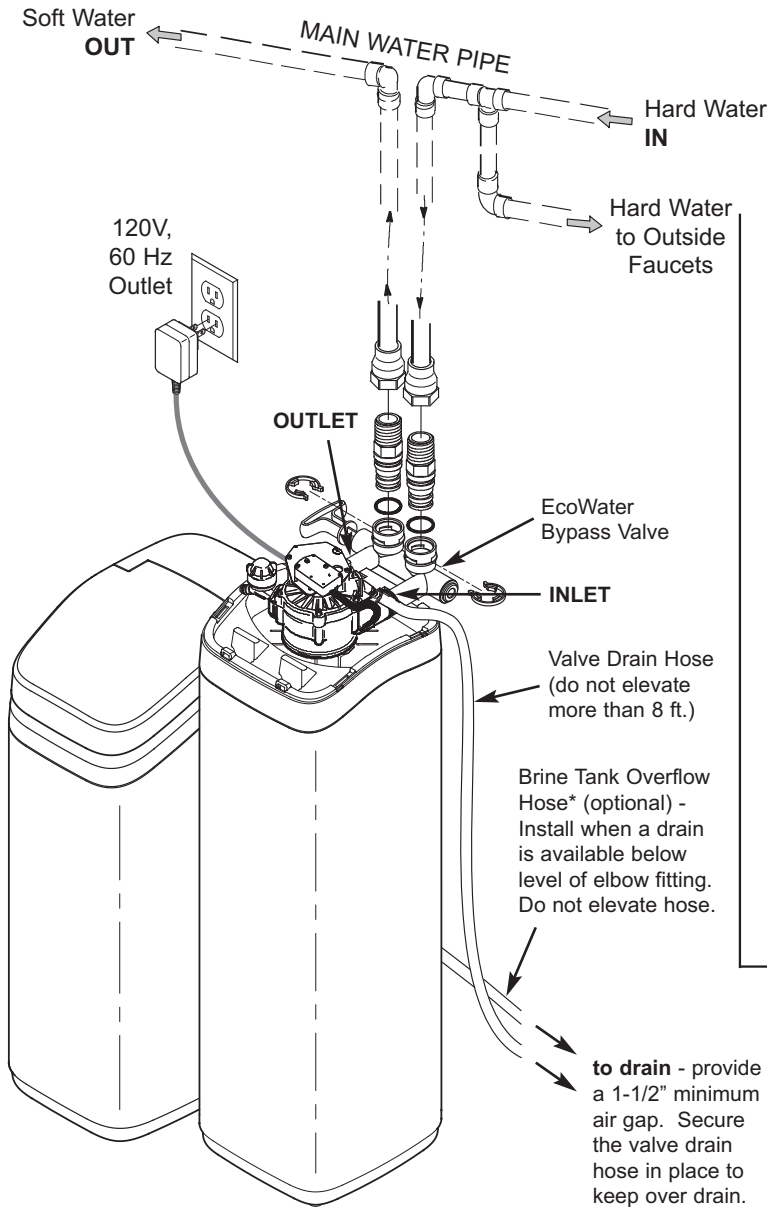


FIG. 5

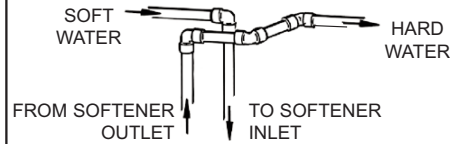
INSTALLATION USING ECOWATER BYPASS VALVE



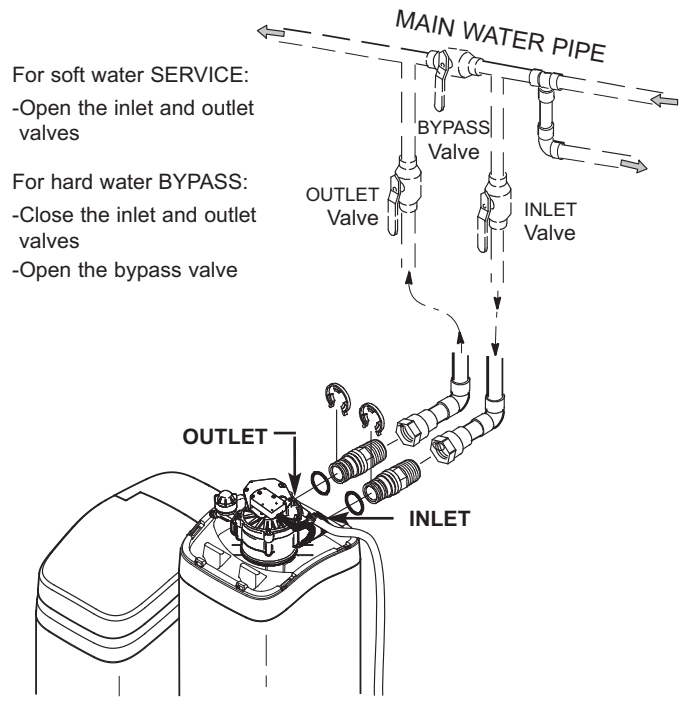
*Do not connect the water softener valve drain hose to the brine tank overflow hose.

CROSS-OVER

Use if water supply flows from the left. Include single or 3-valve bypass.



INSTALLATION USING 3-VALVE BYPASS



CONNECTING A RIGID VALVE DRAIN TUBE

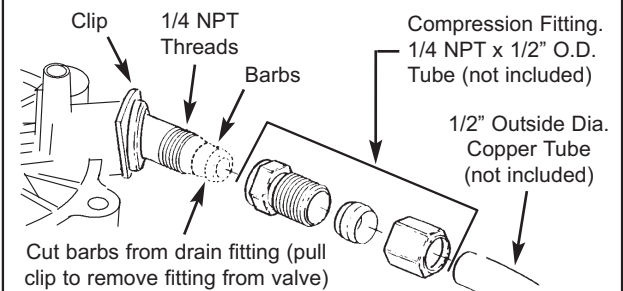


FIG. 6

1. TURN OFF WATER SUPPLY

- a. Close the main water supply valve near the well pump or water meter.
- b. Shut off the electric or fuel supply to the water heater.
- c. Open high and low faucets to drain all water from the house pipes.

2. INSTALL BYPASS VALVE AND/OR PLASTIC INSTALLATION ADAPTORS:

- a. If installing a single bypass valve, push the bypass valve, with lubricated o-ring seals in place, into the valve inlet and outlet ports (See Figure 7).
- OR -
- b. If installing a 3-valve bypass system, slide plastic installation adaptors, with lubricated o-ring seals in place, into the valve inlet and outlet ports, respectively (See Figure 7).
- c. If adding a turbine to the system, be sure the turbine and support are in place in the valve outlet, as shown in Figure 8.
- d. Snap the two large plastic clips in place on the inlet and outlet ports, from the top, down (See Figure 9). Be sure they snap into place. Pull on the bypass valve or installation adaptors, to make sure they are held securely in place.

3. COMPLETE PLUMBING TO AND FROM THE SOFTENER

Using the "Typical Installation Illustration" on page 8 as a guide, observe all of the following cautions while you connect inlet and outlet plumbing:

- Be sure incoming, **hard water** is directed to the valve **INLET** port.
- Be sure to install bypass valve(s).
- If making a soldered copper installation, do all sweat soldering before connecting pipes to the filter fittings. Torch heat will damage plastic parts.
- Use pipe joint compound on all external pipe threads.
- When turning threaded pipe fittings onto plastic fittings, use care not to cross-thread.
- Support inlet and outlet plumbing in some manner (use pipe hangers) to keep the weight off of the valve fittings.

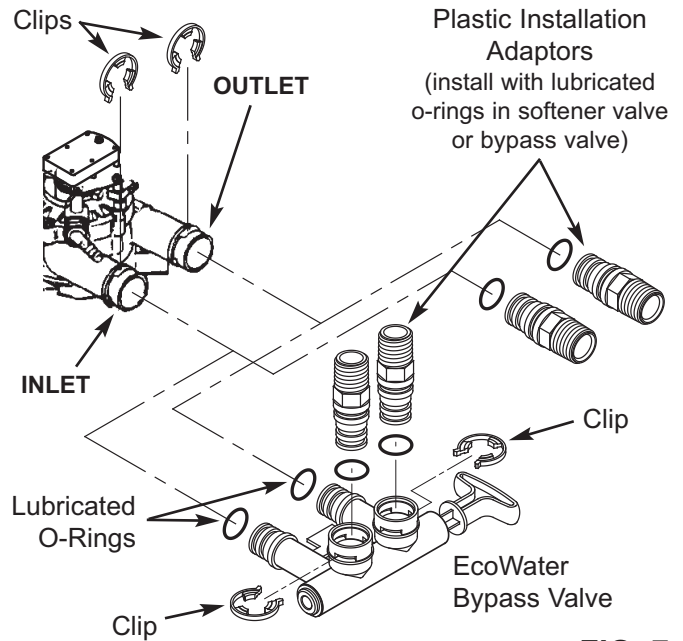


FIG. 7

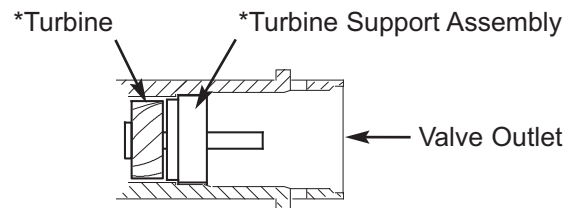


FIG. 8

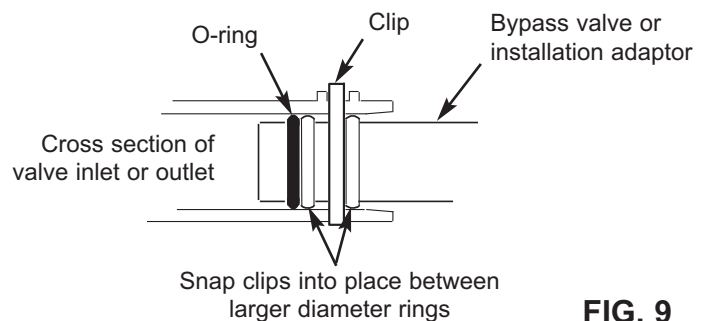


FIG. 9

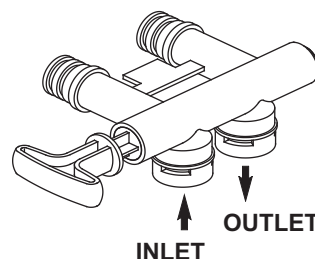
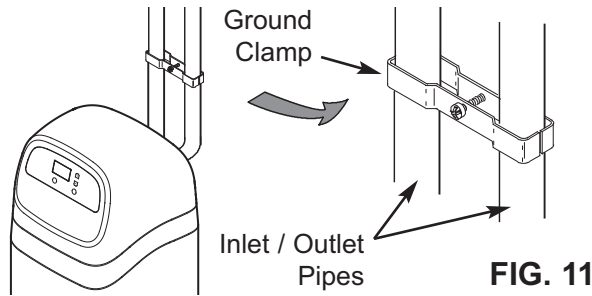


FIG. 10



4. COLD WATER PIPE GROUNDING

The house cold water pipe (metal only) is often used as a ground for the house electrical system. The 3-valve bypass type of installation, shown in Figure 6, will maintain ground continuity. If you use the plastic bypass, continuity is broken. To restore the ground, do either step **4a** or **4b** following.

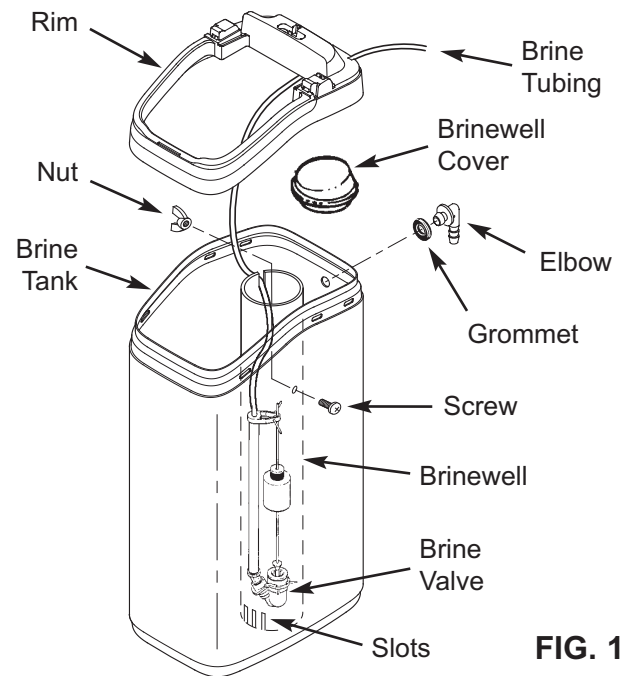
- a. Use the EcoWater ground clamp kit (not included) to make a jumper across the inlet and outlet pipes (See Figure 11).
- b. Install a #4 copper wire across the removed section of main water pipe, securely clamping at both ends – parts not included.

5. INSTALL VALVE DRAIN HOSE

- a. Take a length of 1/2" inside diameter hose and attach to the valve drain fitting, securing it with a hose clamp (See Figure 6 on page 8).
- b. Locate the other end of the hose at a suitable drain point (floor drain, sump, laundry tub, etc.). Check and comply with local codes. Refer to Figure 6 on page 8 if codes require a rigid pipe drain run.

IMPORTANT: Use high quality, thick wall hose that will not easily kink or collapse. The softener will not backwash properly if water cannot exit this hose during recharges.

- c. Tie or wire the hose in place at the drain point. Water pressure will cause it to whip during the backwash portion of the recharge cycle. Also provide an air gap of at least 1-1/2" between the end of the hose and the drain point. An air gap prevents possible siphoning of sewer water, into the softener, if the sewer should back up.
- d. If raising the drain hose overhead is required to get to the drain point, do not raise higher than 8 feet above the floor. Elevating the hose may cause a back pressure that could reduce backwash flow and proper resin bed cleaning.



6. BRINE TANK ASSEMBLY

- a. Snap the rim into place on the brine tank (See Fig. 12).
- b. Lower the brinewell, with the slots at the bottom, into the brine tank. Then use the screw and nut from the parts bag to fasten the brinewell in place along the side of the tank.
- c. Lower the brine valve into the brinewell. Push the tubing into the brinewell top slot (Fig. 12) and route it out through the hole in the back of the rim.
- d. Install the brinewell cover.
- e. Take the rubber grommet and hose adaptor elbow from the parts bag. Push grommet into the hole in the back of the brine tank. Then insert the larger diameter end of the elbow through the grommet.
- f. Snap the brine tank cover assembly onto the rim.

7. INSTALL BRINE TANK OVERFLOW HOSE (OPTIONAL)

This drain is for safety only. If the brine tank should over-fill with water, the excess is carried to the drain.

- a. Take the rubber grommet and hose adaptor elbow from the parts bag. Push grommet into the corresponding hole in the back wall of the brine tank. Then insert the larger diameter end of the elbow through the grommet.
- b. Attach a length of 1/2" inside diameter hose to the drain elbow, installed in the previous step. Use a hose clamp to hold it in place.

continued on next page

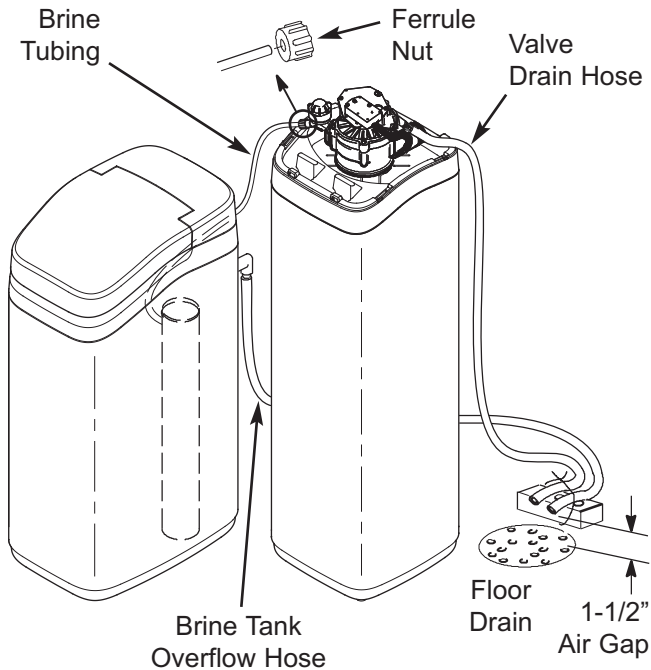


FIG. 13

- c. Locate the other end of the hose at the drain point. Do not elevate this hose higher than the elbow on the brine tank. Do not tee this hose to the valve drain hose.

8. CONNECT BRINE TUBING

- a. Route the brine tube out of the brine tank through the smaller hole in the tank back wall.
- b. Connect the brine tube to the nozzle/venturi assembly using the ferrule nut provided (See Figure 13).

9. PRESSURE TESTING FOR LEAKS, PROGRAMMING THE CONTROLLER & RINSING THE MEDIA

To prevent excessive air pressure in the water softener and plumbing system, do the following steps **EXACTLY** in order:

- a. Fully open two or more **softened** cold water faucets nearby the water softener.
- b. Place the bypass valve(s) in **bypass** position (See Figures 2 & 6).
- c. Fully open the main water supply valve. Watch until the flow from the opened faucets becomes steady, with no spurting or air bubbles.

- d. After about three minutes, open a hot water faucet for one minute, or until all air is expelled.
- e. Close all faucets and check your plumbing work for leaks.
- f. Make sure the softener's valve drain hose is hooked up and the open end directed to a floor drain, laundry tub or other suitable type of drain.
- g. Make sure the softener's bypass valve is in the **bypass** position.
- h. Plug in the power supply.
- i. **Program the electronic controller:** Follow the steps on Pages 13 & 14 (for softeners) or Page 16 (for filters) to program the electronic controller with basic operating information, such as time and water hardness. After completing these steps, continue with "j. Start a recharge", below.
- j. **Start a recharge:** Press the RECHARGE button and hold for 3 seconds, until "Recharge Now" flashes in the display and you hear the valve motor run as the softener begins recharging.
- k. Once the unit is in backwash, place bypass valve(s) into the **service** position, as follows:
 - (1) SINGLE BYPASS VALVE: **Slowly** move the valve stem toward **service** position, pausing several times to allow the unit to pressurize slowly.
 - (2) 3-VALVE BYPASS: Fully close the **bypass** valve and open the **outlet** valve. **Slowly** open the **inlet** valve, pausing several times to allow the unit to pressurize slowly.
- l. Let the softener complete the backwash and fast rinse cycles (takes 10-12 minutes). When the recharge cycle ends, the softener valve returns to the service position.

10. ADD WATER AND SALT TO THE BRINE TANK

- a. Using a pail or garden hose, add about 3 gallons of water into the brine tank. **DO NOT** pour into the brinewell.
- b. Add salt to the brine tank. It is recommended to fill the brine tank no more than 1/2 full. Level the salt when finished adding. You can use most water softener salts, but it must be clean. Recommended nugget, pellet or coarse solar salts have less than 1% impurities.

NOTE: See page 20 for additional information on salt.

11. SANITIZING THE WATER SOFTENER

Care is taken at the factory to keep your EcoWater Systems water softener clean and sanitary. However, during shipping, storage, installing and operating, bacteria could get into the unit. For this reason, sanitizing as follows is suggested* when installing.

- a. Remove the brinewell cover and pour about 1-1/2 oz. (2 to 3 tablespoons) of common household bleach into the softener's brinewell. Replace the brinewell cover.
- b. Make sure the bypass valve is in the **service** position.
- c. **Start a recharge:** Press the RECHARGE button and hold for 3 seconds, until "Recharge Now" flashes in the display and you hear the valve motor run as the softener begins recharging. This recharge draws the sanitizing bleach into and through the softener. Any air remaining in the unit is purged to the drain.
- d. After the recharge has completed, fully open a cold water faucet, downstream from the softener, and allow 50 gallons of water to pass through the system. This should take at least 20 minutes. Close the faucet.

12. RESTART THE WATER HEATER

Turn on the electric or fuel supply to the water heater, and light the pilot, if applies.

NOTE: The water heater is filled with hard water and, as hot water is used, it refills with softened water. In a few days, the hot water will be fully conditioned. To have fully conditioned hot water immediately, wait until the recharge (Step 11) is complete, then drain the water heater until water runs cold.

*Recommended by the Water Quality Association. On some water supplies, the EcoWater Systems unit may need periodic disinfecting.

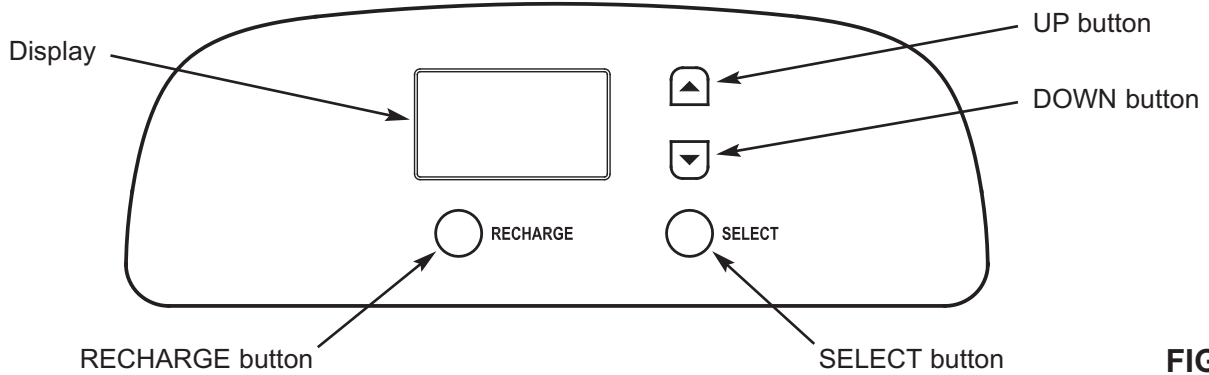


FIG. 14

CONTROLLER SETTINGS REQUIRED

upon installation, and after an extended power outage.

When the power supply is plugged into the electrical outlet, a model code (example: ST31) and a version number (example: J3.9), are briefly shown in the display. For softener or tannin filter use, you must select the correct model code, as shown below.

SET MODEL CODE

1. Press and hold for 3 seconds the SELECT button, until the display shows "000 - -" (See Figure 15).



FIG. 15

2. Press and hold for 3 seconds the SELECT button once again until a model code appears in the display.

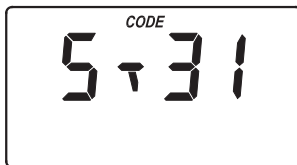


FIG. 16

3. Press the ▲ UP or ▼ DOWN buttons to select the correct model code for softener or tannin filter use. See the table below.

Model Code	Amount of Resin	Tank Size
ST31	1 cu. ft.	10" x 47"
ST39	1-1/4 cu. ft.	10" x 47"
STAn	use for tannin filters	

4. With the correct model code displayed, press the SELECT button to restart the controller. Follow the programming steps below to set the timer for softener use. **If you are using the unit as a tannin filter, go to the programming steps on Page 16.**

SET PRESENT TIME OF DAY

1. If the words "PRESENT TIME" do not show in the display, press the SELECT button several times until they do.

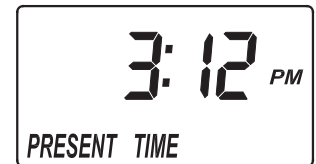


FIG. 17

2. Press the ▲ UP or ▼ DOWN buttons to set the present time. Up moves the display ahead; down sets the time back. Be sure AM or PM is correct.

NOTE: Press buttons and quickly release to slowly advance the display. Hold the buttons down for fast advance.

3. When the correct time is displayed, press the SELECT button, and the display will change to show the "Hardness" screen.

continued on next page

SET WATER HARDNESS NUMBER

1. If you completed the previous step, the word "HARDNESS" should show in the display (See Figure 18). Otherwise, press the SELECT button several times until it does.



FIG. 18

2. Press the ▲ UP or ▼ DOWN buttons to set the value of your water's hardness in grains per gallon (gpg). Hardness level can be turned OFF by pressing the ▼ DOWN button below 1. This would be chosen if you wished to have the softener recharge at a specific number of days.

NOTE: If your water supply contains iron, compensate for it by adding to the water hardness number. For example, assume your water is 20 gpg hard and contains 2 ppm iron. Add 5 to the hardness number for each 1 ppm of iron. In this example, you would use 30 for your hardness number.

$$\begin{array}{r}
 20 \text{ gpg hardness} \\
 2 \text{ ppm iron} \times 5 = 10 \text{ } \underline{+10} \\
 \text{(times)} \qquad \qquad \qquad 30 \text{ HARDNESS NUMBER}
 \end{array}$$

2. When finished setting your water's hardness number, press the SELECT button. If a hardness number is selected, the next setup screen to appear will be "Set Number of People". If "OFF" is selected, the next setup screen to appear will be "Set Days Between Recharges".

SET NUMBER OF PEOPLE

If a hardness level was set in the previous step, you will set the Number of People in the household.



FIG. 19

1. Press the ▲ UP or ▼ DOWN buttons to set the number of people. The factory default is 4.
2. When the correct number of people is displayed, press the SELECT button, and the display will change to show the "Set Recharge Time" screen.

SET DAYS BETWEEN RECHARGES

If a hardness level was set to "OFF", you must set the Number of Days Between Recharges.



FIG. 20

1. Press the ▲ UP or ▼ DOWN buttons to set the number of days.
2. When the correct number of days is displayed, press the SELECT button, and the display will change to show the "Set Recharge Time" screen.

SET REGENERATION STARTING TIME

1. If you completed the previous steps, the words "RECHARGE TIME" should show in the display (See Figure 21). Otherwise, press the SELECT button several times until they do.

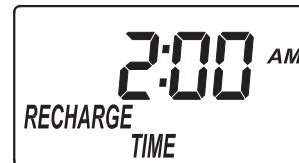


FIG. 21

2. The softener's default regeneration start time is 2:00 AM. In most households this is a good time for regeneration to start (takes about 2 hours) because water is not being used. During regeneration hard water is bypassed to house faucets. Use the ▲ UP or ▼ DOWN buttons to adjust the recharge start time in 1 hour increments.
3. When the desired regeneration time is displayed, press the SELECT button, and the display will change to show the normal run time display.



FIG. 22

SET CAPACITY

The electronic controller determines this number, based on the initial timer programming.

Setting	Softening Capacity	Salt Use	Water Use
CAP 1	Lowest	Most salt efficient	Regenerates more often
CAP 2	Medium	Medium	Medium
CAP 3	Highest	Uses most salt	Regenerates less often

If you want to change the capacity, do the following:

1. Press and hold for 3 seconds the SELECT button, until the display shows "000 - -".
2. Once in this display, press the SELECT button once and "CAP" will show in the display.

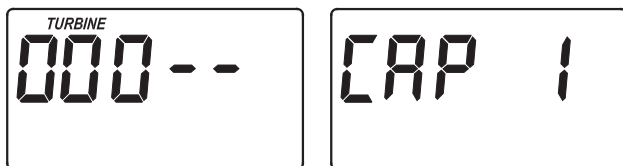


FIG. 23

3. Press the ▲ UP or ▼ DOWN buttons to set the capacity number.
4. Press the SELECT button several times to return advance through the remaining screens and return to the normal run (time of day) display.

VIEW DAYS TO RECHARGE

This view-only display shows the number of days the softener will run before the next recharge. This display will not be available if Hardness was set to OFF (as described on the previous page).

1. Press and hold the SELECT button, until the display shows "000 - -".
2. Press the SELECT button twice and "Recharge" will show in the display.

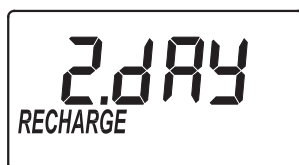


FIG. 24

3. Press the SELECT button several times to return advance through the remaining screens and return to the normal run (time of day) display.

12 OR 24 HOUR CLOCK

The timer has been factory preset to display a 12 hour (AM/PM) clock. If you prefer, you may change this to display a 24 hour clock.

1. Press and hold the SELECT button, until the display shows "000 - -".
2. Press the SELECT button three times and "12 hr" will flash in the display.

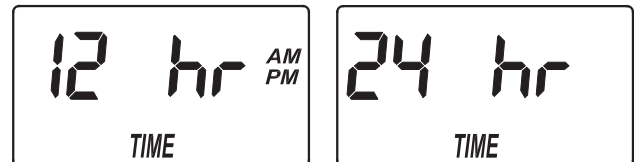


FIG. 25

3. Use the ▲ UP button to change to a 24 hour clock display.
4. Press the SELECT button several times to advance through the remaining screens and return to the normal operation (time of day) display.
5. To change back to a 12 hour clock, follow Steps 1 through 4, above, except use the ▼ DOWN button in Step 3.

ADJUST BACKWASH AND RINSE TIME

The timer can be changed to allow different backwash and fast rinse times, if so desired. Each of these can be adjusted from 0 to 99 minutes.

1. Press and hold the SELECT button until "000 - -" shows in the display.
2. Press the SELECT button four times and "bA-" will appear in the display, followed by the current backwash time, in minutes, flashing.
3. Use the ▲ UP or ▼ DOWN buttons to set the number of minutes desired for backwash.

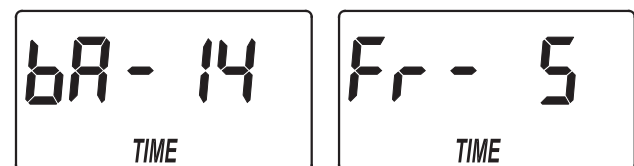


FIG. 26

4. Press the SELECT button again and "Fr-" will appear in the display, followed by the current fast rinse time, in minutes, flashing.
5. Use the ▲ UP or ▼ DOWN buttons to set the number of minutes desired for fast rinse.
6. Press the SELECT button several times to return advance through the remaining screens and return to the normal run (time of day) display.

Complete the following programming steps if you set the model code to “STAn”, as described on Page 13, to use the unit as a tannin filter.

SET PRESENT TIME OF DAY

1. If the words “PRESENT TIME” do not show in the display, press the SELECT button several times until they do.

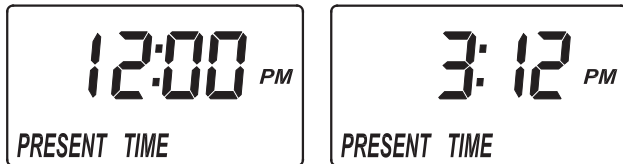


FIG. 27

2. Press the ▲ UP or ▼ DOWN buttons to set the present time. Up moves the display ahead; down sets the time back. Be sure AM or PM is correct.
3. When the correct time is displayed, press the SELECT button, and the display will change to show the “Recharge” screen.

SET DAYS BETWEEN RECHARGES

This setting is the number of days the filter will go between recharges. The default setting is 2 days, with a maximum setting of 99 days.

1. If you completed the previous steps, the words “RECHARGE” and “day” should show in the display (See Figure 28). Otherwise, press the SELECT button several times until they do.



FIG. 28

2. Press the ▲ UP or ▼ DOWN buttons to set the number of days.
3. When the correct number of days is displayed, press the SELECT button, and the display will change to show the “Set Recharge Time” screen.

SET REGENERATION STARTING TIME

1. If you completed the previous steps, the words “RECHARGE TIME” should show in the display (See Figure 29). Otherwise, press the SELECT button several times until they do.

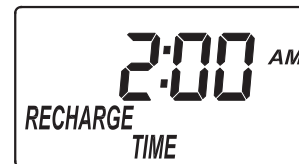


FIG. 29

2. The filter’s default regeneration start time is 2:00 AM. In most households this is a good time for regeneration to start because water is not being used. During regeneration hard water is bypassed to house faucets. Use the ▲ UP or ▼ DOWN buttons to adjust the recharge start time in 1 hour increments.
3. When the desired regeneration time is displayed, press the SELECT button, and the display will change to show the normal run time display.



FIG. 30

ADJUSTABLE FILL

1. Press and hold for 3 seconds the SELECT button, until the display shows “000 - -”.
2. Once in this display, press the SELECT button once and “F” will appear in the display, followed by the current fill time, in minutes, flashing.
3. Press the ▲ UP or ▼ DOWN buttons to set the fill time, from 0 to 99:59 minutes.
4. Press the SELECT button several times to return advance through the remaining screens and return to the normal run (time of day) display.

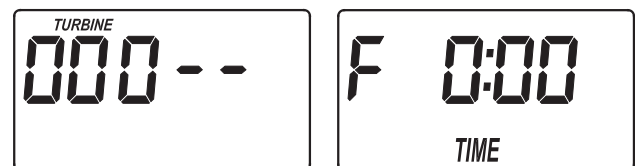


FIG. 31

continued on next page

ADJUSTABLE BRINE DRAW

1. Press and hold the SELECT button, until the display shows “000 - -”.
2. Press the SELECT button twice and “dr” will appear in the display, followed by the current brine draw time, in minutes, flashing.

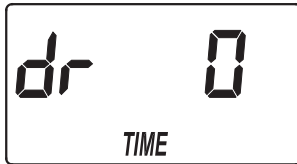


FIG. 32

3. Press the ▲ UP or ▼ DOWN buttons to set the brine draw time, from 0 to 255 minutes.
4. Press the SELECT button several times to return advance through the remaining screens and return to the normal run (time of day) display.

12 OR 24 HOUR CLOCK

The timer has been factory preset to display a 12 hour (AM/PM) clock. If you prefer, you may change this to display a 24 hour clock.

1. Press and hold the SELECT button, until the display shows “000 - -”.
2. Press the SELECT button three times and “12 hr” will flash in the display.

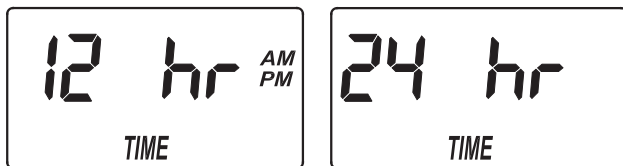


FIG. 33

3. Use the ▲ UP button to change to a 24 hour clock display.
4. Press the SELECT button several times to advance through the remaining screens and return to the normal operation (time of day) display.
5. To change back to a 12 hour clock, follow Steps 1 through 4, above, except use the ▼ DOWN button in Step 3.

ADJUSTABLE BACKWASH TIME

1. Press and hold the SELECT button until “000 - -” shows in the display.
2. Press the SELECT button four times and “bA-” will appear in the display, followed by the current backwash time, in minutes, flashing.

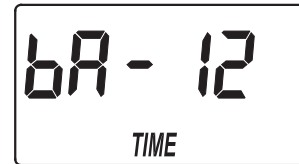


FIG. 34

3. Use the ▲ UP or ▼ DOWN buttons to set the number of minutes desired for backwash, from 0 to 99 minutes.
4. Press the SELECT button several times to return advance through the remaining screens and return to the normal run (time of day) display.

ADJUSTABLE FAST RINSE TIME

1. Press and hold the SELECT button until “000 - -” shows in the display.
2. Press the SELECT button five times and “Fr-” will appear in the display, followed by the current fast rinse time, in minutes, flashing.

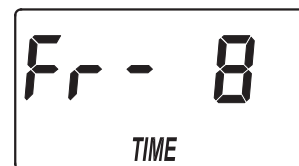


FIG. 35

3. Use the ▲ UP or ▼ DOWN buttons to set the number of minutes desired for fast rinse, from 0 to 99 minutes.
6. Press the SELECT button several times to return advance through the remaining screens and return to the normal run (time of day) display.

AUXILIARY OUTPUT CONTROL

The electronic controller’s auxiliary output may be used to operate various types of external equipment, such as a chlorine generator or chemical feeder. It provides a 24V DC, up to 500 mA, current from terminal J4 on the electronic control board (see Schematic

on the next page). The table on the next page explains the choices available for when the auxiliary output will be on during various portions of the recharge cycle.

continued on next page

SELECTION	NAME	AUXILIARY OUTPUT FUNCTION
OFF	Off	Remains off indefinitely.
BP	Bypass	On during the entire recharge.
CL	Chlorine	On during the brine draw portion of the recharge.
FS	Flow Switch	On when water is flowing past the turbine*. It will shut off 8 seconds after water flow stops.
CF	Chemical Feeder	After the set volume of water has flowed past the turbine*, turns on for the time set (see Steps 4 & 5, below, to set volume and time).
FR	Fast Rinse	On during the fast rinse portion of the recharge.

The default is OFF. If you wish to change to one of the other selections shown in the table:

1. Press and hold the SELECT button until "000 - -" shows in the display (See Figure 36).



FIG. 36

2. Press the SELECT button several times, until "Ctrl" flashes in the display (See Figure 37).

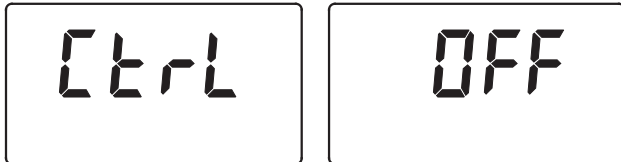


FIG. 37

3. Use the ▲ UP or ▼ DOWN buttons to display the desired selection, then press the SELECT button. If you selected anything other than CF, the display will return to the normal run (time of day) screen. If setting to CF (Chemical Feeder), there will be two additional settings to make for operating the chemical feeder in Steps 4 and 5, below.

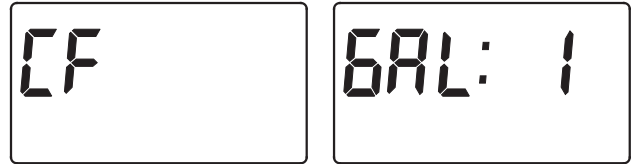


FIG. 38

4. **CHEMICAL FEEDER TRIP VOLUME:** If you have set the auxiliary output control to CF (Chemical Feeder), you will need to set the volume of water which must flow past the turbine* before the auxiliary output is turned on. With the alternating screens in Fig. 38 shown, use the ▲ UP or ▼ DOWN buttons to set the trip volume, in gallons. Then press the SELECT button to display the screen shown in Fig. 39.

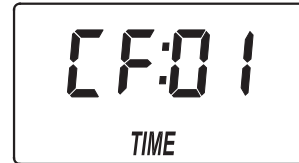


FIG. 39

5. **CHEMICAL FEEDER TIME:** Use the ▲ UP or ▼ DOWN buttons to set the length of time, in seconds, that the auxiliary output will be turned on. Then press the SELECT button to accept and return to the normal run (time of day) screen.

* A turbine and turbine cable must be added to the system if auxiliary output selections "FS" or "CF" are to be used.

WIRING SCHEMATIC

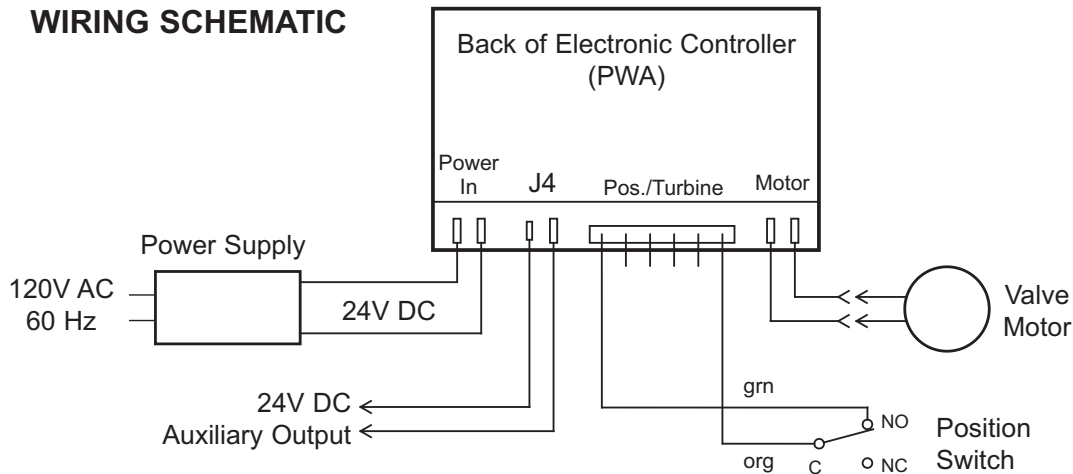


FIG. 40

NORMAL OPERATION

During normal operation, the present time of day shows in the display.



FIG. 41

POWER OUTAGE MEMORY

If electrical power to the softener/filter's control is lost, internal memory will maintain most settings such as the hardness and recharge time. However, unless the power outage was very brief, the clock's present time will need to be reset. During a power outage, the display will be blank and the unit will not recharge. When electrical power is restored:

1. Check the display.
- 2a. If the present time is displayed steadily (not flashing), the controller did not lose time and you do not need to reset the clock.
- 2b. If a time is flashing in the display, then the clock needs to be reset to the correct present time. See "Set Present Time of Day" on page 13. The flashing display is to remind you to reset the clock. If you do not reset the clock, then recharges will most likely occur at the wrong time of day.

NOTE: If the unit was recharging when power was lost, it will finish the cycle when power returns.

RECHARGE NOW

For times when you expect to use more water than usual, it may be desirable to perform a manually initiated recharge. To manually start a recharge cycle, press and hold the RECHARGE button for a few seconds, until "RECHARGE NOW" flashes in the display.



FIG. 42

The softener/filter begins an immediate recharge. Once started, you cannot cancel this recharge. Avoid using hot water during this time, as the water heater will refill with hard/unfiltered water.

VACATION MODE

Before going on vacation, or any other long absence, press and release (do not hold) the RECHARGE button, so "VAC" begins flashing in the display.



FIG. 43

In vacation mode the electronic controller continues to keep time, but recharges will not occur using water and salt.

When you return, press and release (do not hold) the RECHARGE button to turn off the vacation mode and return the softener/filter to normal operation. The time of day screen (See Fig. 41) will then be displayed. **Remember to do this**, or the unit will not recharge and you will soon have hard/unfiltered water.

REFILLING WITH SALT

If the softener uses all the salt before more is added, hard water will result. Remove the brine tank lid and check the salt level frequently. Until you have established a refilling routine, check the salt every 2 or 3 weeks. Be sure that the brinewell cover is on when adding salt.

NOTE: In humid areas it is best to keep the salt level less than half full and refill more often.

RECOMMENDED SALT: Cube, pellet, coarse solar, etc., water softener salt is recommended. This type of salt is high purity evaporated crystals, sometimes formed and pressed into briquets. It has less than 1% insoluble (not dissolvable in water) impurities. Clean, high grade rock salts are acceptable, but may require frequent brine tank cleaning to remove the "sludge" residue (insolubles) collecting at the bottom of the tank.

POTASSIUM CHLORIDE: If you choose potassium chloride (KCl) salt instead of standard sodium chloride (NaCl) water softener salt as a regenerant:

- 1) The hardness setting must be increased by 25%.
- 2) Place only one bag of potassium chloride (KCl) into your water softener at a time. The salt storage tank should never contain more than 60 pounds of KCl.

SALT NOT RECOMMENDED: Rock salt high in impurities, block, granulated, table, ice melting, or ice cream making salts, etc., are not recommended.

SALT WITH IRON REMOVING ADDITIVE: Some salts have an additive to help a water softener handle iron in the water supply. Although this may help keep the resin bed clean, it may also release corrosive fumes that will weaken and shorten the life of some EcoWater Systems softener electronic parts. Iron Out salt is safe to use on two-tank models.

BREAKING A SALT BRIDGE

Sometimes a hard crust or salt "bridge" forms in the brine tank. This is usually caused by high humidity or the wrong kind of salt. When the salt bridges, an empty space forms between the water and the salt. Then salt will not dissolve in the water to make brine. Without brine, the resin bed is not recharged and hard water will result.

If the storage tank is full of salt, it is difficult to tell whether there is a salt bridge. A bridge may be underneath loose salt. The following is the best way to check for a salt bridge:

Salt should be loose all the way to the bottom of the tank. Hold a broom handle, or like tool, up to the softener's brine tank, as shown in Figure 44. Make a pencil mark on the handle 1" - 2" below the top of the rim. Then, carefully push it straight down into the salt. If a hard object is felt before the pencil mark is even with the top, it is most likely a salt bridge. Carefully push into the bridge in several places to break it. **Do not try to break the salt bridge by pounding on the outside of the salt tank. You may damage the tank.**

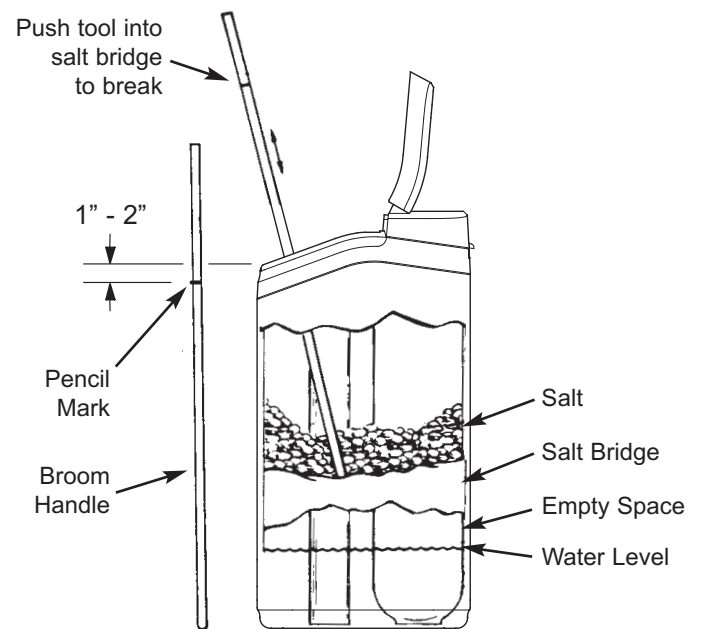


FIG. 44

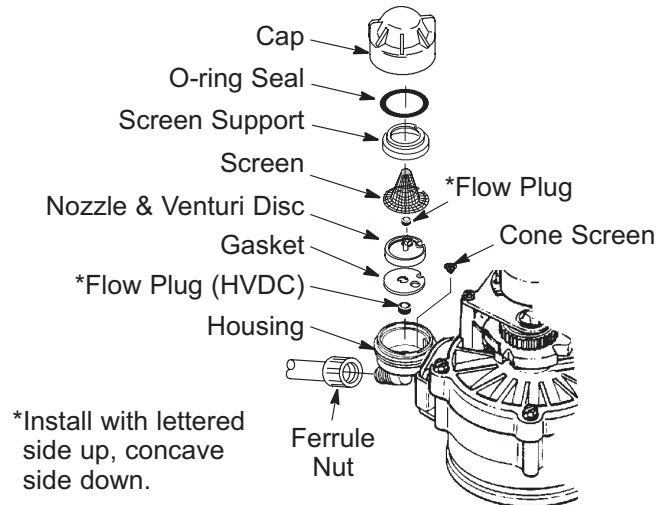
CLEANING THE NOZZLE & VENTURI

A clean nozzle & venturi (See Figure 45) is a necessity for the water softener to work properly. This small component creates the suction to aspirate (bring air into) the mineral tank during recharges. If it should become plugged with sand, silt, dirt, etc., the water softener will not work, and hard water will result.

To get access to the nozzle & venturi, remove the water softener's top cover. Put the bypass valve(s) into the bypass position. Be sure the water softener's main valve is in "service" position (no water pressure at nozzle & venturi). Then, holding the nozzle & venturi housing with one hand, unscrew the cap. Do not lose the o-ring seal. Lift out the screen support and screen. Then, remove the nozzle & venturi disc, gasket and flow plug. Wash the parts in warm, soapy water and rinse in fresh water. Be sure to clean both the top and bottom of the nozzle & venturi disc. If needed, use a small brush to remove iron or dirt. Do not scratch, misshape, etc., surfaces of the nozzle & venturi.

Gently replace all parts in the correct order. Lubricate the o-ring seal with silicone grease and locate in place. Install and tighten the cap by hand, while supporting the housing. Overtightening may break the cap or housing. Put the bypass valve(s) into "service" position.

Recharge the softener to reduce water level in the tank. This will also assure that the softener is completely recharged and ready to provide softened water again. Check the water level in the tank by looking down the brinewell. If the water level does not drop after a recharge, the problem has not been resolved.



IMPORTANT: Be sure small hole in the gasket is centered directly over the small hole in the nozzle & venturi housing. Be sure the numbers are facing up

FIG. 45

RESIN BED CLEANING

If the water supply contains clear water iron, regular resin bed cleaning is needed to keep the bed from coating with iron. Use resin bed cleaner, available from EcoWater Systems, following directions on the container. Clean the resin every six months, or more often if iron appears in the conditioned water supply.

AUTOMATIC ELECTRONIC DIAGNOSTICS

This softener has a self-diagnostic function for the electrical system. The computer monitors electronic components and circuits for correct operation. If a malfunction occurs, an error code appears in the display.



FIG. 46

The chart below shows the error codes that could appear, and the possible malfunctions for each code.

Code	Possible Problems
Err01	Motor, Valve Position Switch
Err03	Motor, Valve Position Switch, Wire Harness
Err04	Valve Position Switch
Err05	Electronic Control Board (PWA)

While an error code appears in the display, all buttons are inoperable except the SELECT button. SELECT remains operational so the service person can perform the Manually Initiated Electronic Diagnostics to further isolate the problem.

TO REMOVE AN ERROR CODE:

1. Unplug the power supply.
2. Correct the problem.
3. Plug the power supply back in.
4. Wait for at least 8 minutes while the timer operates the valve through an entire cycle. The error code will return if the problem was not corrected.

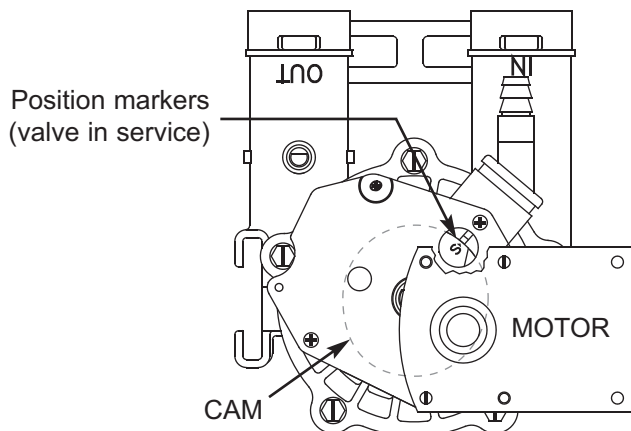


FIG. 47

MANUALLY INITIATED ELECTRONIC DIAGNOSTICS

Use the following procedures to advance the softener through the recharge cycles to check operation.

Remove the top cover by unlocking the tabs and tilting it forward, to observe cam and switch operation during valve rotation.

1. Press and hold for 3 seconds the SELECT button, until one of the screens shown in Figure 48 is displayed.

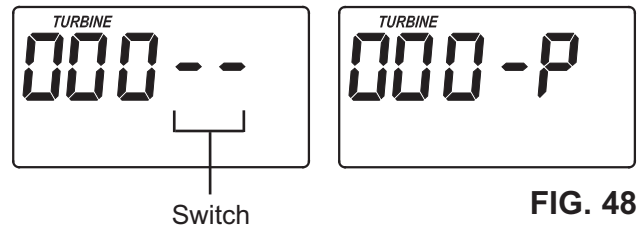


FIG. 48

2. The last 2 digits in the display indicate POSITION switch operation as follows:

Correct Switch Displays	Valve Cycle Status
--	Valve in service, fill, brining, backwash or fast rinse position.
- P	Valve rotating from one position to another.

3. Use the RECHARGE button to manually advance the valve into each position and check correct switch operation (See Figures 50-54).
4. While in this diagnostic screen, the following information is available and may be beneficial for various reasons. This information is retained by the computer from the first time electrical power is applied to the electronic controller.
 - a. Press the ▲ UP button to display the number of days this electronic control has had electrical power applied.
 - b. Press the ▼ DOWN button to display the number of automatic or manual recharges initiated by this electronic control since the model code number was entered.
5. Press the SELECT button and hold in for 3 seconds until the model code shows in the display. See the table on Page 13 for model codes. If the wrong number shows, the softener will operate on incorrect configuration data.
6. To change the code number - Press the ▲ UP or ▼ DOWN button until the correct code shows.

continued on next page

continued from previous page

- To return to the present time display, press the SELECT button. **If the model code was changed, make all controller settings.**

NOTE: If the electronic control is left in a diagnostic display (or a flashing display when setting times or hardness), present time automatically returns if a button is not pressed within 4 minutes.

RESETTING TO FACTORY DEFAULTS

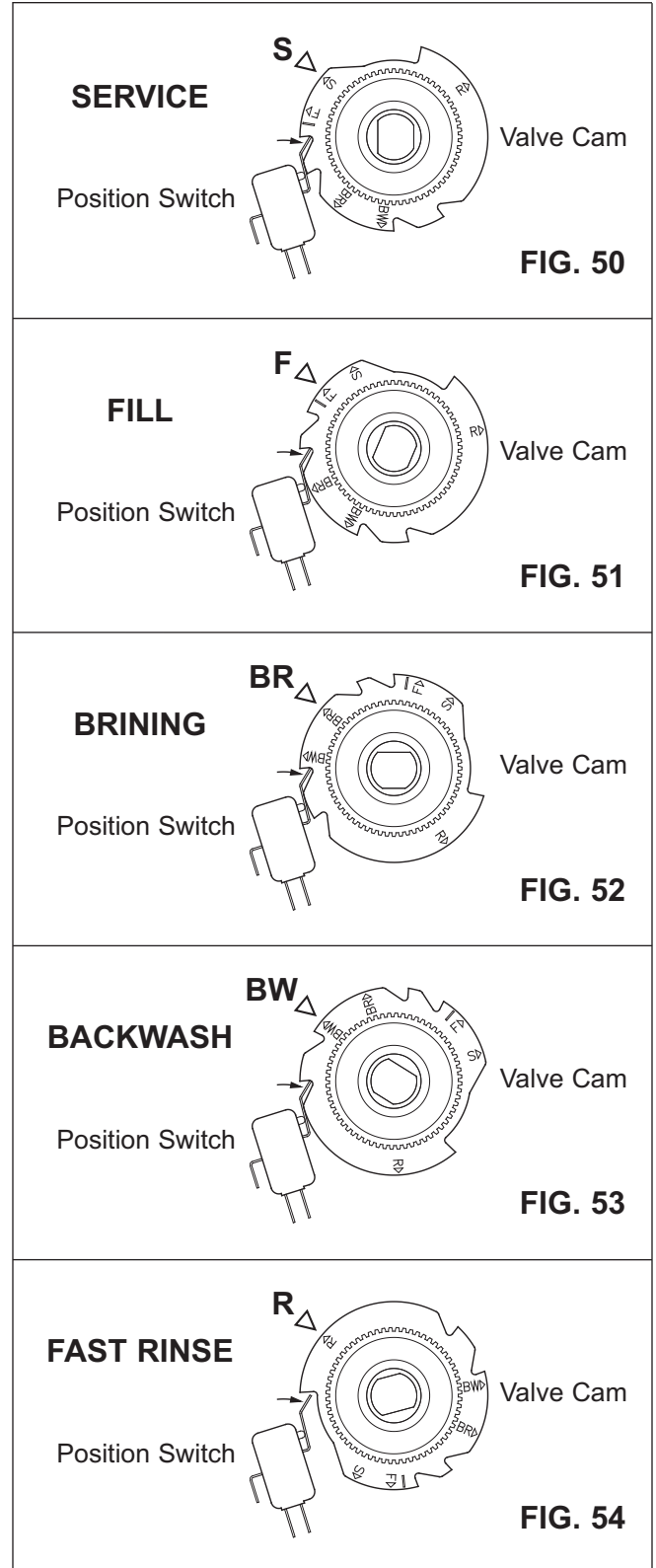
To reset the electronic controller to its factory default for all settings (time, days between recharges, etc.):

- Press the SELECT button and hold it until the display changes twice to show "CODE" and the flashing model code.
- Press the ▲ UP button (a few times, if necessary) to display a flashing "SoS".

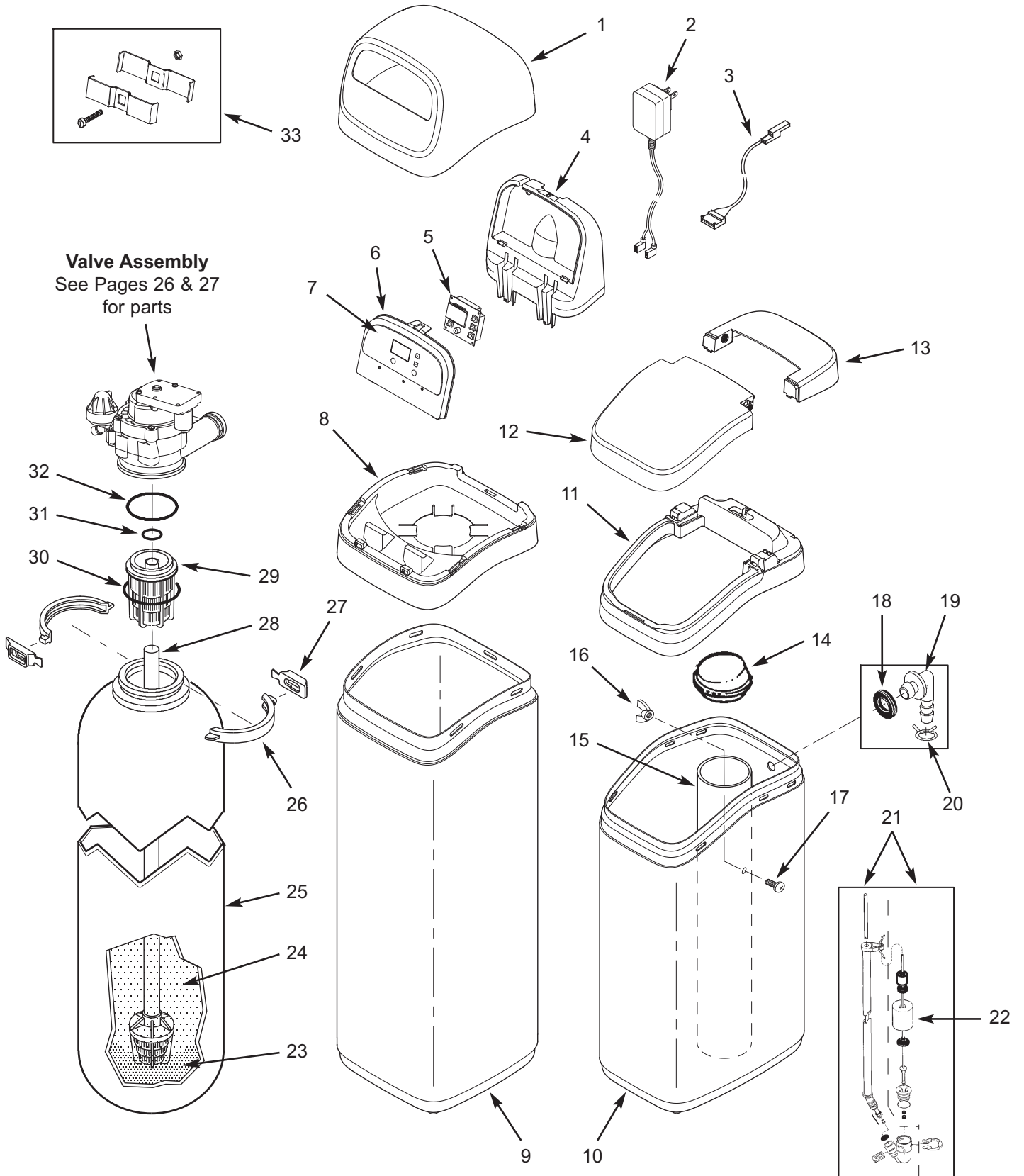


FIG. 49

- Press the SELECT button, and the electronic controller will restart.
- Set the present time, hardness / days between recharges, etc., as described on pages 13 & 14 (for softeners) or page 16 (for filters).



SYSTEM EXPLODED VIEW



SYSTEM PARTS LIST

Key No.	Part No.	Description
1	7353365	Cover, Top
2	7351054	Power Supply, 24V DC
3	7259927	Wire Harness, Position Switch
4	7353381	Support, Faceplate
5	7356290	Repl. Electronic Controller (PWA)
6	7366986	Faceplate (order decal below)
7	7368792	Decal, Faceplate
8	7368857	Rim
9	7353234	Shroud, 47"
10	7353187	Brine Tank, Blow Molded ♦
	7384887	Brine Tank, Injection Molded
11	7368865	Rim, for Blow Molded Brine Tank ♦
	7387128	Rim, for Injection Molded Brine Tank
-	7364162	Cover Assembly, Brine Tank (includes Key Nos. 12 & 13)
12	↑	Salt Lid
13	↑	Cover, Brine Tank
■	7259935	Decal, Instruction
14	7155115	Cover, Brinewell
15	7109871	Brinewell
-	7357822	Brinewell Mounting Hardware Kit, (includes Key Nos. 16 & 17)
16	↑	Nut
17	↑	Screw

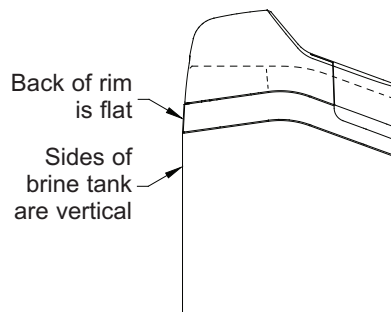
Key No.	Part No.	Description
-	7331258	Overflow Hose Adaptor Kit (includes Key Nos. 18-20)
18	↑	Grommet
19	↑	Adaptor Elbow
20	↑	Hose Clamp
21	7310210	Brine Valve Assembly
22	7327568	Float, Stem & Guide Assembly
23	7124415	Gravel, 17 lbs. *
24	0502272	Resin, 1 cu. ft. (standard mesh) *
25	7092202	Resin Tank, 10" dia. x 47"
-	7331177	Tank Neck Clamp Kit (includes 2 ea. of Key Nos. 26 & 27)
26	↑	Clamp Section (2 req.)
27	↑	Retainer Clip (2 req.)
28	7105047	Repl. Bottom Distributor
29	7077870	Top Distributor
-	7112963	Distributor O-Ring Kit (includes Key Nos. 30-32)
30	↑	O-Ring, 2-3/4" x 3"
31	↑	O-Ring, 13/16" x 1-1/16"
32	↑	O-Ring, 2-7/8" x 3-1/4"
33	7248706	Ground Clamp Kit *

♦ Blow molded brine tanks were used exclusively prior to 2022, and on some units manufactured later. Rims for blow molded brine tanks will only fit that type, and rims for injection molded brine tanks will only fit that type. See illustration below.

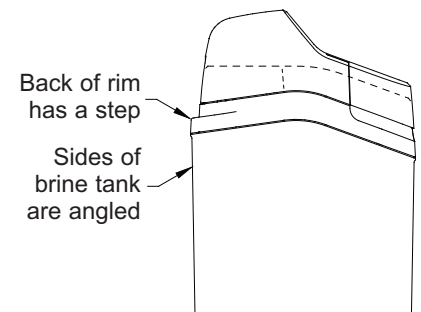
■ Not illustrated.

* Not included with the system.

BLOW MOLDED

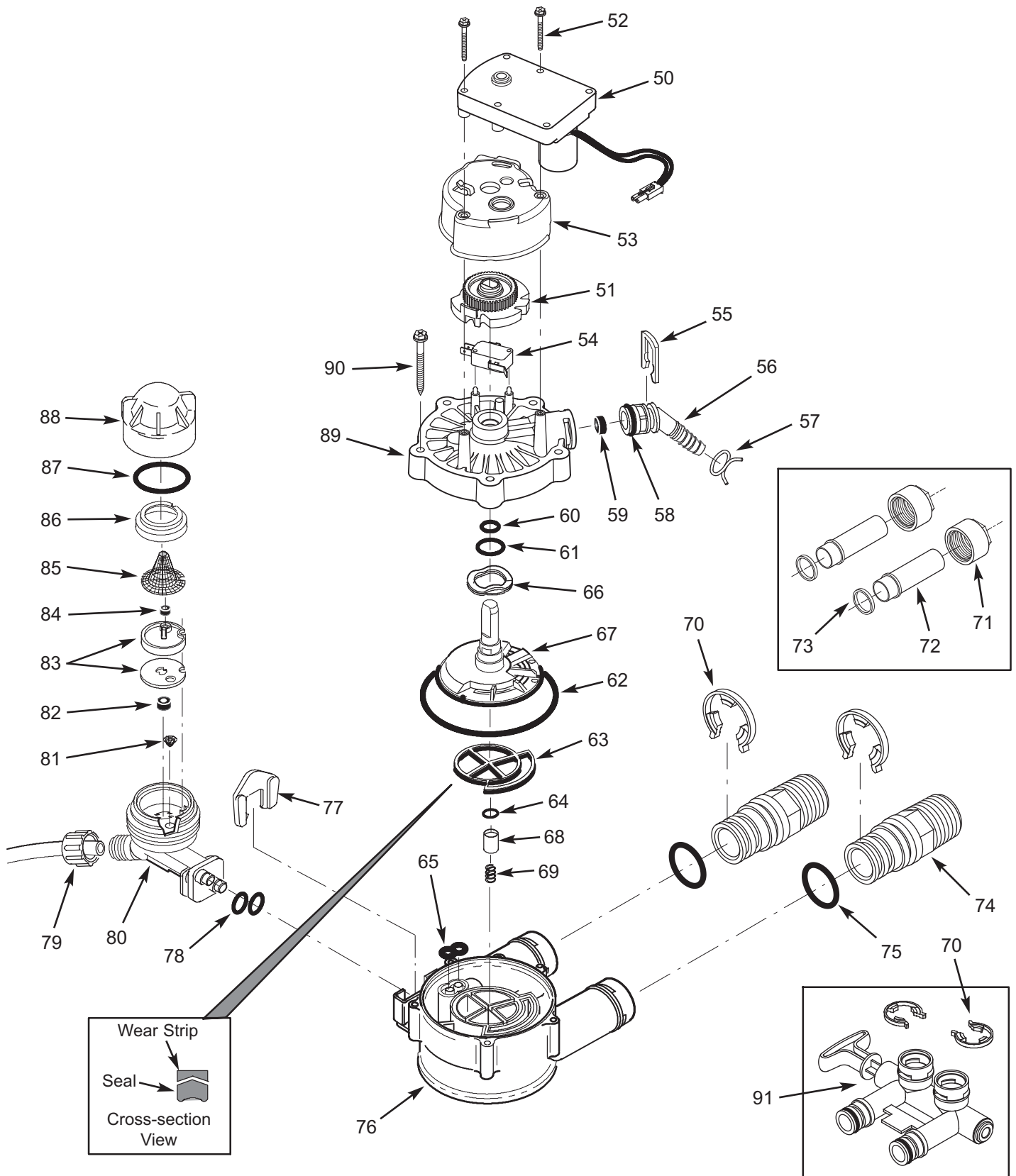


INJECTION MOLDED



To order parts, call your local EcoWater dealer or go to www.ecowater.com to locate a dealer in your area.

VALVE EXPLODED VIEW



VALVE PARTS LIST

Key No.	Part No.	Description
–	7384683	Motor, Cam & Gear Kit, 3/4" (includes Key Nos. 50-52)
50	↑	Motor
51	↑	Cam & Gear
52	7338111	Screw, #6-19 x 1-3/8" (2 req.)
53	7337474	Motor Mount
54	7030713	Switch
–	7332157	Drain Hose Adaptor Kit (includes Key Nos. 55-59)
55	↑	Clip, Drain
56	↑	Drain Hose Adaptor
57	↑	Hose Clamp
58	↑	O-Ring, 5/8" x 13/16"
59	↑	Flow Plug, 2.2 gpm
–	7129716	Seal Kit (includes Key Nos. 60-65)
60	↑	O-Ring, 7/16" x 5/8"
61	↑	O-Ring, 3/4" x 15/16"
62	↑	O-Ring, 3-3/8" x 3-5/8"
63	↑	Rotor Seal
64	↑	O-Ring, 3/8" x 9/16"
65	↑	Seal, Nozzle & Venturi
66	7082087	Wave Washer
67	7199232	Rotor & Disc
68	7092642	Plug, Drain Seal
69	7129889	Spring
70	7116713	Clip, 3/4", single (4 req.)
	7336397	Clip, 3/4", pack of 20
–	7344146	Copper Tube Kit, 3/4", * (includes 10 ea. of Key Nos. 71-73)
71	0507369	Installation Nut * (2 req.)
72	0507615	Installation Tube, 3/4" * (2 req.)
73	7170335	Washer * (2 req.)

Key No.	Part No.	Description
74	7271238	Installation Adaptor, 3/4", single (2 req.)
	7336606	Installation Adaptor, 3/4", pack of 10, including O-Rings & Silicone Grease (See Key No. 75)
75	7390668	O-Ring, 15/16" x 1-3/16", pack of 2, including Silicone Grease
	7336402	O-Ring, 15/16" x 1-3/16", pack of 20
76	7082053	Valve Body
77	7081201	Retainer, Nozzle & Venturi
78	7170319	O-Ring, 1/4" x 3/8" (2 req.)
79	1202600	Nut - Ferrule
–	7257454	Nozzle & Venturi Assembly (incl. Key Nos. 77, 78 & 80-88)
80	7081104	Housing, Nozzle & Venturi
81	7095030	Cone Screen
82	1148800	Flow Plug, .3 gpm
83	7114533	Nozzle & Venturi Kit w/Gasket
	7204362	Gasket only, single
	7336486	Gasket only, pack of 20
84	7084607	Flow Plug, .15 gpm
85	7146043	Screen
86	7167659	Screen Support
87	7170262	O-Ring, 1-1/8" x 1-3/8", single
	7336436	O-Ring, 1-1/8" x 1-3/8", pack of 20
88	7199729	Cap
89	7337466	Valve Cover
90	7074123	Screw, #10-14 x 2" (5 req.)
91	7278434	Bypass Valve, 3/4", Clip Style * (includes 2 ea. of Key No. 75)
■	7129871	Bypass Valve, 3/4", Threaded * (includes 2 ea. of Key No. 75)

■ Not illustrated.

* Not included with the system.

To order parts, call your local EcoWater dealer or go to
www.ecowater.com to locate a dealer in your area.